

FORCED AIR MIDGET MIXERS

MM & EMM SERIES

FEATURES

- Mixer body: brass
- Adequate for different types of gas: CH₄ /L.P./propane
- Adequate for: different types of fuel
- Air and gas inlets: separated and adjustable
- Construction: rugged and compact

APPLICATIONS

- Pilot burner.
- Premixed burners up to 40 KW (in stoichiometric ratio)

DESCRIPTION

MM and EMM are suction type proportional air-gas mixers. The quantity of gas entrained is easily set by the adjuster plug in the gas throttle orifice. Once set, the fuel to air ratio remains constant over a wide range of air flows.

A Zero Regulator can be used to maintain a constant gas pressure, precisely at atmospheric pressure, for all gas flows. The pressure of the mixture delivered to the burner system and therefore the capacity is controlled by a single valve in the combustion air line.



F235101

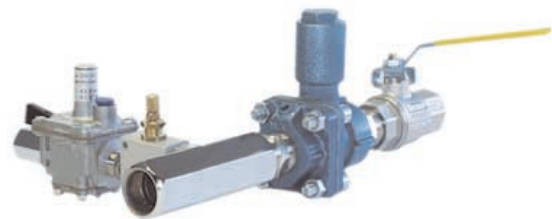

F235102

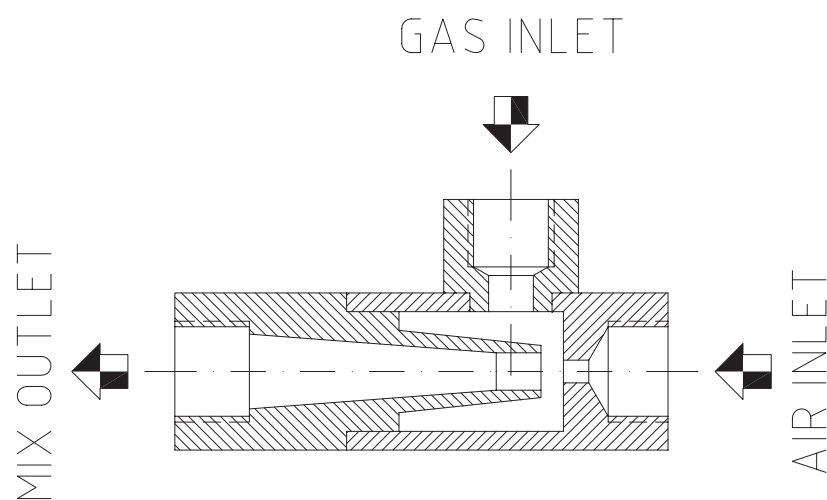

D235101



Headquarters
Esa S.r.l.
Via E. Fermi 40 I-24035 Curno (BG) - Italy
Tel. +39.035.6227411 - Fax +39.035.6227499
esa@esacombustion.it - www.esapyronics.com

International Sales
Pyronics International S.A./N.V.
Zoning Ind., 4ème rue B-6040 Jumet - Belgium
Tel +32.71.256970 - Fax +32.71.256979
marketing@pyronics.be

INSTALLATION

- The mixer (without the Zero Regulator) may be mounted to work in any position.
- The diaphragm case of the gas regulator must be horizontal.
- The gas and air piping connections are marked on the mixer bodies. Piping to these connections should be sized large enough to minimize pressure losses.
- The Zero Regulator should be mounted as close as possible to the gas ratio throttle orifices.
- A single Zero Regulator should be mounted on every mixer.
- The distance between the Zero Regulator and the mixer should be as short as possible to minimize pressure losses which must never exceed 0.25 mbar.
- Piping from the mixer outlet to burner or burners must be at least as large as the mixer outlet pipe. No valves or other restriction are permitted in this pipe. Pressure losses in this pipe must never exceed 1.25 mbar.
- To light burners, open fully gas throttle orifice, open air cock, apply lighter to burners and adjust gas throttle for desired flame.

MIDGET MIXER SELECTION

- The capacities listed are based on 100% primary air operation.
- Determine the maximum capacity of the burner or burners to be used with each mixer at the mixer pressure corresponding to the air pressure available.
- Multiply the total capacity by the primary aeration percentage (air/gas ratio) required by the burners.
- Select the correct Midget Mixer based on this capacity. If the selection capacity falls between two sizes, select the smaller size.
- Select the Maxitrol or BZR Series Regulator based on the capacity of the burners and of the type of gas.

CAPACITY TABLE

Model	Minimum downstream port area (mm ²)	Capacity (kW)				
		Air pressure (mbar)				
		3.5	17.6	35.2	70.4	105.6
		Mixture pressure (mbar)				
		1	5	10	20	30
1 MM	17.0	0.5	1.0	1.5	2.1	2.5
2 MM	33.2	0.9	2.1	2.9	4.1	5.0
3 MM	43.3	1.2	2.6	3.5	5.3	6.4
4 MM	62.6	1.8	4.1	5.6	7.9	9.7
6 MM	117	3.3	7.3	10.3	14.7	17.9
8 MM	161	6.4	14.7	20.5	29.3	35.2
8 EMM Ø 8.5	201	5.7	12.8	18.0	25.5	31.2
8 EMM Ø 11.5	247	10.9	24.5	34.6	49.0	60.0

DIMENSIONS

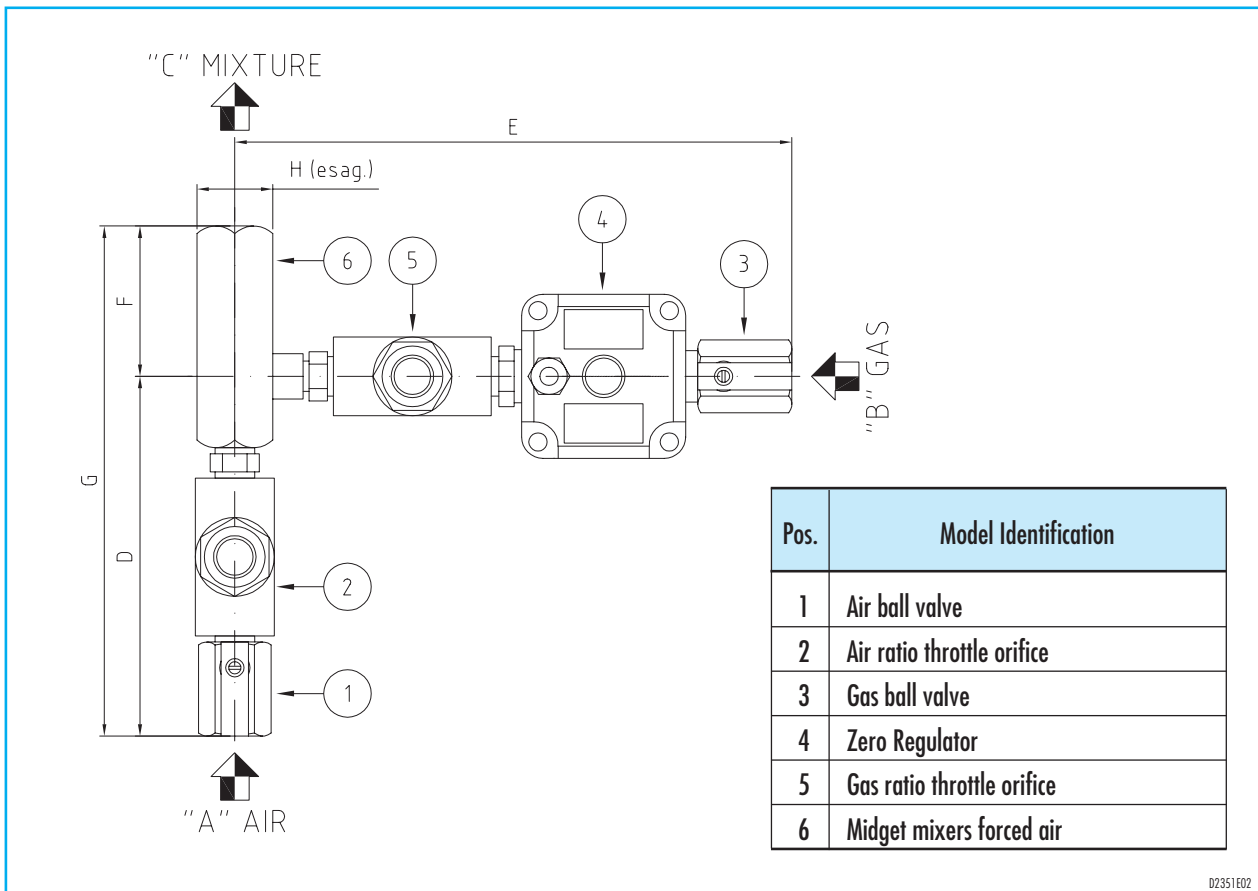

Model	Items	ø A	ø B	ø C	D mm	E mm	F mm	G mm	H mm	Mass kg
1 MM	6	G - 1/4"	G - 1/4"	G - 1/8"	24	27	38	62	25	0.220
2 MM	6	G - 1/4"	G - 1/4"	G - 1/4"	22	27	51	73	25	0.270
1 MMS-II	3-5-6	G - 1/4"	G - 1/4"	G - 1/8"	24	110	38	62	25	0.420
2 MMS-II	3-5-6	G - 1/4"	G - 1/4"	G - 1/4"	22	120	51	73	25	0.460
1 MMC-II	1-3-5-6	G - 1/4"	G - 1/4"	G - 1/8"	70	110	38	108	25	0.530
2 MMC-II	1-3-5-6	G - 1/4"	G - 1/4"	G - 1/4"	68	120	51	118	25	0.570
1 MMT-II	1-2-3-5-6	G - 1/4"	G - 1/4"	G - 1/8"	120	110	38	158	25	0.610
2 MMT-II	1-2-3-5-6	G - 1/4"	G - 1/4"	G - 1/4"	117	120	51	168	25	0.660
1 MMSR-II	3-4-5-6	G - 1/4"	G - 3/8"	G - 1/8"	24	165	38	62	25	0.640
2 MMSR-II	3-4-5-6	G - 1/4"	G - 3/8"	G - 1/4"	22	185	51	73	25	0.680
1 MMCR-II	1-3-4-5-6	G - 1/4"	G - 3/8"	G - 1/8"	70	165	38	108	25	0.750
2 MMCR-II	1-3-4-5-6	G - 1/4"	G - 3/8"	G - 1/4"	68	185	51	118	25	0.790
1 MMTR-II	1-2-3-4-5-6	G - 1/4"	G - 3/8"	G - 1/8"	120	165	38	158	25	0.830
2 MMTR-II	1-2-3-4-5-6	G - 1/4"	G - 3/8"	G - 1/4"	117	185	51	168	25	0.870

DIMENSIONS

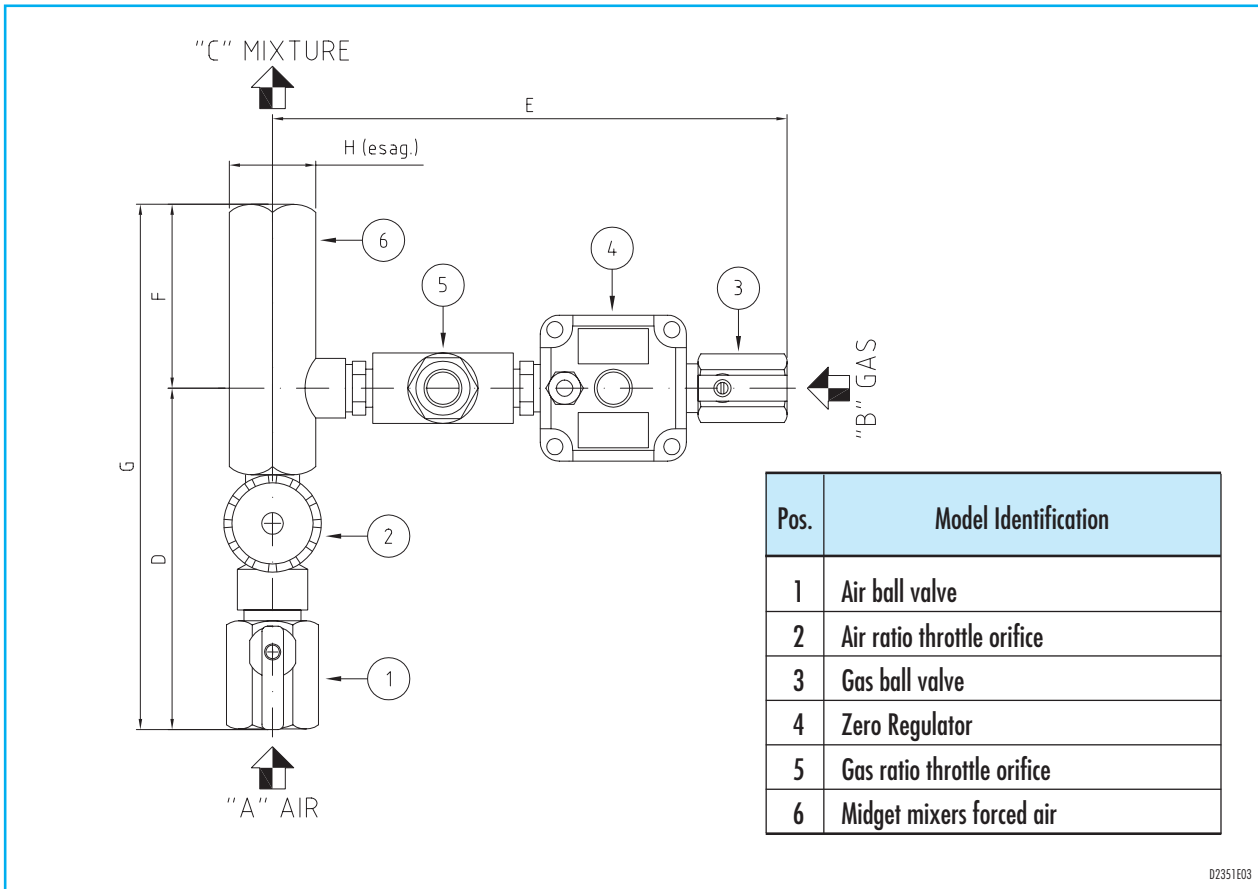

Model	Items	ø A	ø B	ø C	D mm	E mm	F mm	G mm	H mm	Mass kg
3 MM	6	G - 3/8"	G - 1/4"	G - 3/8"	23	28	60	83	25	0.290
4 MM	6	G - 1/2"	G - 3/8"	G - 1/2"	31	32	67	98	32	0.510
3 MMS-II	3-5-6	G - 3/8"	G - 1/4"	G - 3/8"	23	120	60	83	25	0.480
4 MMS-II	3-5-6	G - 1/2"	G - 3/8"	G - 1/2"	31	140	67	98	32	0.720
3 MMC-II	1-3-5-6	G - 3/8"	G - 1/4"	G - 3/8"	55	120	60	115	25	0.610
4 MMC-II	1-3-5-6	G - 1/2"	G - 3/8"	G - 1/2"	73	140	67	140	32	0.930
3 MMT-II	1-2-3-5-6	G - 3/8"	G - 1/4"	G - 3/8"	100	120	60	160	25	0.690
4 MMT-II	1-2-3-5-6	G - 1/2"	G - 3/8"	G - 1/2"	118	140	67	185	32	1.020
3 MMSR-II	3-4-5-6	G - 3/8"	G - 3/8"	G - 3/8"	23	185	60	83	25	0.700
4 MMSR-II	3-4-5-6	G - 1/2"	G - 3/8"	G - 1/2"	31	195	67	98	32	0.930
3 MMCR-II	1-3-4-5-6	G - 3/8"	G - 3/8"	G - 3/8"	55	185	60	115	25	0.830
4 MMCR-II	1-3-4-5-6	G - 1/2"	G - 3/8"	G - 1/2"	73	195	67	140	32	1.140
3 MMTR-II	1-2-3-4-5-6	G - 3/8"	G - 3/8"	G - 3/8"	100	185	60	160	25	0.910
4 MMTR-II	1-2-3-4-5-6	G - 1/2"	G - 3/8"	G - 1/2"	118	195	67	185	32	1.230

DIMENSIONS

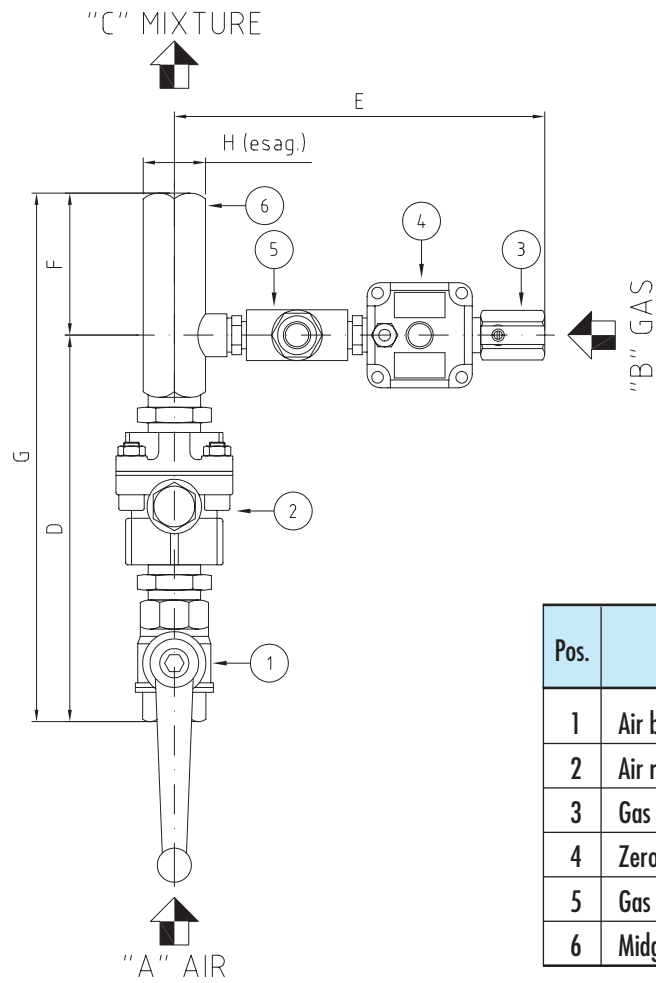

Pos.	Model Identification
1	Air ball valve
2	Air ratio throttle orifice
3	Gas ball valve
4	Zero Regulator
5	Gas ratio throttle orifice
6	Midget mixers forced air

D2351/04

DIMENSIONS

Model	Items	ø A	ø B	ø C	D mm	E mm	F mm	G mm	H mm	Mass kg
6 MM	6	G - 3/4"	G - 3/8"	G - 3/4"	32	32	73	105	32	0.490
8 MM	6	G - 1"	G - 3/8"	G - 1"	43	40	87	130	40	1.230
6 MMS-II	3-5-6	G - 3/4"	G - 3/8"	G - 3/4"	32	140	73	105	32	0.700
8 MMS-II	by request	—	—	—	—	—	—	—	—	—
6 MMC-II	1-3-5-6	G - 3/4"	G - 3/8"	G - 3/4"	105	140	73	178	32	1.040
8 MMC-II	by request	—	—	—	—	—	—	—	—	—
6 MMT-II	1-2-3-5-6	G - 3/4"	G - 3/8"	G - 3/4"	192	140	73	265	32	1.440
8 MMT-II	by request	—	—	—	—	—	—	—	—	—
6 MMSR-II	3-4-5-6	G - 3/4"	G - 3/8"	G - 3/4"	32	195	73	105	32	0.910
8 MMSR-II	by request	—	—	—	—	—	—	—	—	—
6 MMCR-II	1-3-4-5-6	G - 3/4"	G - 3/8"	G - 3/4"	105	195	73	178	32	1.260
8 MMCR-II	by request	—	—	—	—	—	—	—	—	—
6 MMTR-II	1-2-3-4-5-6	G - 3/4"	G - 3/8"	G - 3/4"	192	195	73	265	32	1.660
8 MMTR-II	by request	—	—	—	—	—	—	—	—	—

DIMENSIONS 8EMM

FLANGED VERSION

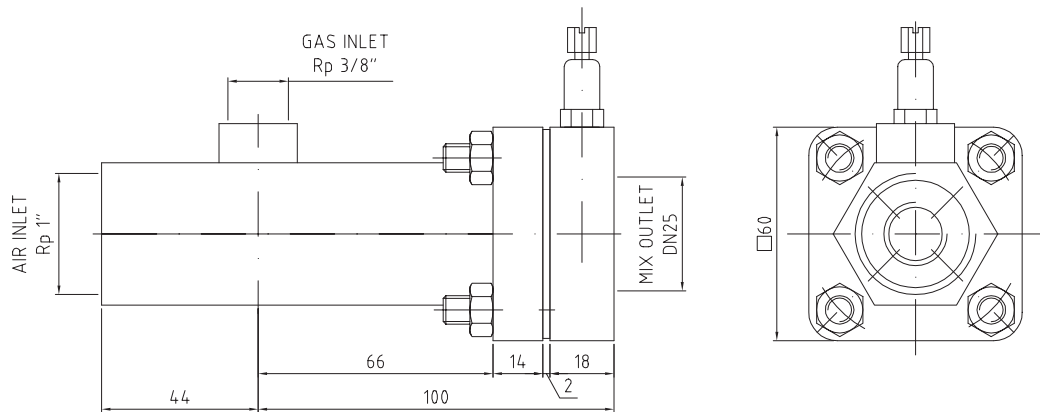

THREADED VERSION

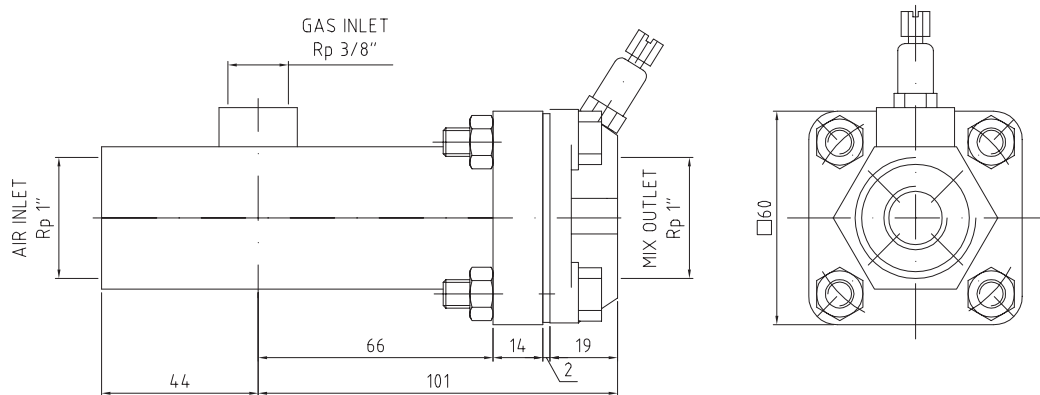

D2351105