

# VENTURI MIXERS FLOMIXERS SERIES

## FEATURES

- Construction: compact in aluminium
- Max. air pressure: 145 mbar
- Max. mixture pressure: 56 mbar
- Wide modulating range.

## APPLICATIONS

- Adequate to all burners.

## INSTALLATION

- Use of flange connections eliminating unions in gas and air lines.
- Easy accessibility of entrainment insert for inspection, cleaning or changing capacity without disconnecting gas or air lines.
- Universal type gas adjuster-good for any kind of gas.
- Ample pressure test plugs to facilitate checking air pressure, gas suction and mixture pressure.
- Output mixture pipes to the FLOMIXERS with inserts bigger than 54 must be expanded to diam.6" (DN 150) before connecting to the general manifold.
- It is advisable to size mixture pipes correctly; pressure drops should not exceed 2.5 mbar.

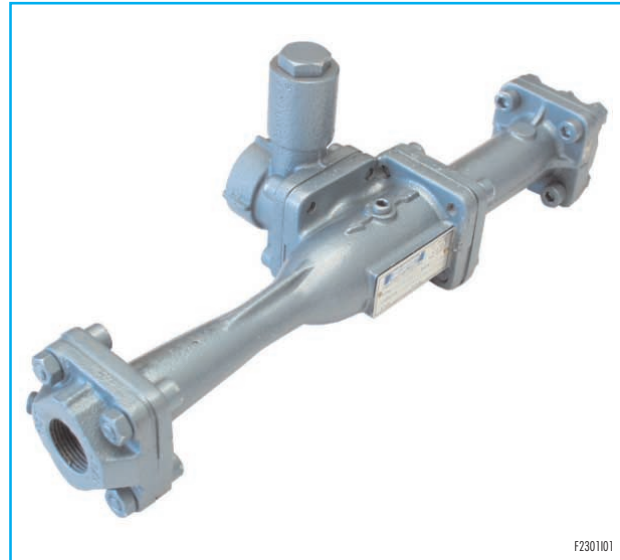

F230101

## DESCRIPTION

Flomixers are proportional mixing devices that utilize the energy of a stream of air to suction the combustible gas and to deliver the mixture (Venturi effect).

Referring to the sketch (fig. no. 1), Flomixer operation may be described as follows: air at any available pressure (P1) passes through the air sleeve "A" into the air jet "B", where it develops the maximum possible velocity. This stream of air moving at high speed creates a suction (P2) of about -5 mbar in the chamber "C". This strong suction draws gas from the zero pressure chamber "E"

Figure 1

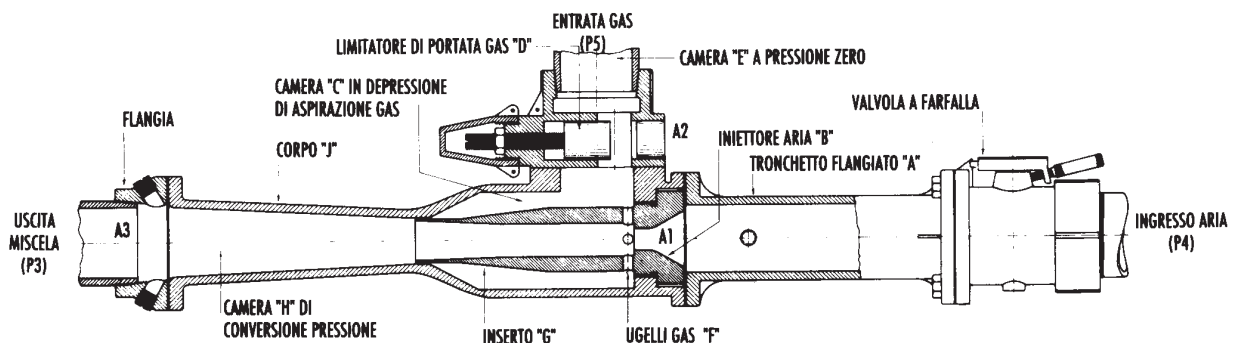

F2301E02



**Headquarters**  
Esa S.r.l.  
Via E. Fermi 40 I-24035 Curno (BG) - Italy  
Tel. +39.035.6227411 - Fax +39.035.6227499  
esa@esacombustion.it - www.esapyronics.com

**International Sales**  
Pyronics International S.A./N.V.  
Zoning Ind., 4ème rue B-6040 Jumet - Belgium  
Tel +32.71.256970 - Fax +32.71.256979  
marketing@pyronics.be

through the gas adjuster "D", chamber "C" and gas ports "F" into the space around the air stream in insert "G". The mixture flows into the pressure conversion chamber "H" (P3) and is delivered from the outlet flange to the manifold piping and burners. The quantity of gas entrained is obviously proportional to the suction effect which varies according to the air inlet pressure.

The flomixer responds to all of the varying forces exerted upon it, (air and gas pressures, piping, effective burner areas, etc.). Since the capacity is in equilibrium with other variables, any change in one will cause a corresponding change in the others. Therefore the air and gas ratio stays constantly balanced if the three pressures, that is air (P1), gas (P2) and mixture (P3) pressures and the three sections, that is air (A1), gas (A2) and mixture (A3) stay adequately balanced among them (fig.2).

Flomixer capacity ratings are based on correct burners (A3) to air jet area (A1) relations. In order to secure satisfactory performance from combinations of burners and flomixers, it is important that they be correctly matched in capacity or have the correct relationship between the flomixer air jet and the total effective burner port area.

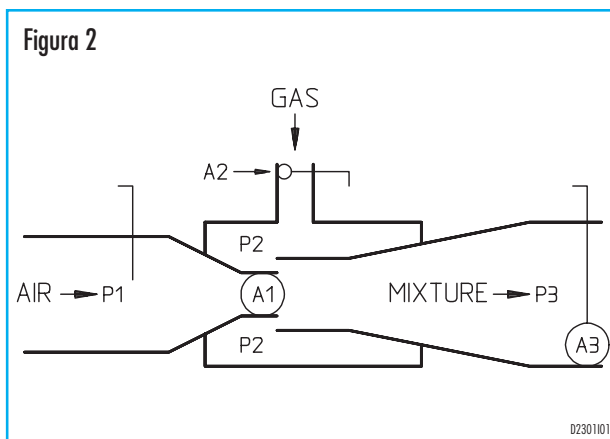

The selection of the proper flomixer depending on the sections may be very difficult unless the true discharge coefficient is known. This coefficient stands for the capacity of the burner which acts as an orifice, because the gas fuel flowing through it has a pressure drop at that point.

The adjustment of the capacity in systems working with a flomixer may be done by adjusting only the air pressure; as a matter of fact the gas inspired depends on the program set for the gas adjuster (A2). When the air jet area (A1) is correctly sized in relation to the burners area (A3), a good, stable negative pressure P2 is always

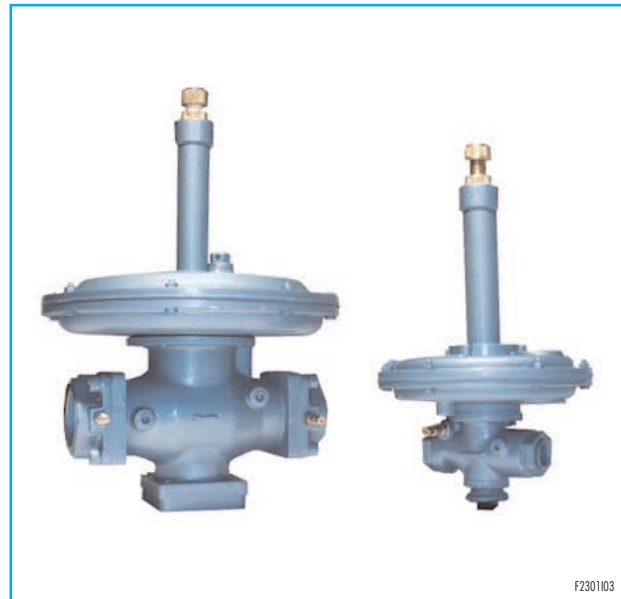

obtained. If the mixture pressure P3 is too high, a positive pressure occurs in P2 and therefore the mixer does not work correctly any longer.

Every pressure drop between the mixer outlet and the burners entails an increase in pressure P3. For this reason the mixture piping size must be adequate to the capacity and have as few restrictions, joints or elbows as possible so that pressure losses downstream of the mixer are less than 2.5 mbar. Flomixers may be used to obtain any mixture with 75% to 100% aeration.

Flomixers are characterized by complete flexibility of right and left - up or down installation without special parts, so all parts in each series are interchangeable, easy accessibility of entrainment insert for inspection, cleaning or changing capacity without disconnecting gas or air lines. The table in the following pages shows the maximum insert range for each series. It is recommended, however, that only the insert sizes specified in the capacity table I be used. If larger inserts are used, excessive velocity and friction pressure losses in the mixture piping may occur.

A correctly sized zero regulator may be mounted. When flomixers are used in groups and utilize a single zero regulator it is essential, for accurate air-gas proportioning, that the gas pressure at the adjuster inlets be held at zero.

This requires not only an accurate zero regulator but proper sizing of the gas lines between regulator and mixers.

N.B. For further information on Zero Regulators, consult technical bulletin E5101.

## FLOMIXER SELECTION

Use one of the following methods:

- CAPACITY BASIS - 100% AERATION.

For applications requiring a complete air-gas mixture, that is 100% primary air. Knowing the desired capacity (kW) and the type of fuel gas, the flomixer is selected directly from Table I under the air pressure column. If the correct air pressure falls between listed air pressures, the selection procedure is changed as follows:

$$\text{Capacity} \times \frac{\sqrt{\text{Air pressure (Table)}}}{\sqrt{\text{Air pressure (actual)}}} = \text{Selection capacity}$$

- CAPACITY BASIS - LESS THAN 100% AERATION.

For applications where less than 100% primary air mixtures are required. Knowing the desired kW capacity and percentage aeration, a new flomixer "selection capacity" is computed. Multiplying the kW capacity by the aeration percentage gives the new figure (Multiplier for 80% aeration is 0.8). Using this new figure, the flomixer is selected from Table I under the air pressure column.

- BURNER AREA BASIS.

Knowing the number, size, and type of burners required, determine the total port area and correct this area for burner discharge coefficient (using Table II, divide burner area by discharge coefficient). When burners and flomixers are matched on the area relationship basis, capacities shown in the flomixer table are for complete air-gas mixtures. For operation at other air-gas ratios, the corrected burner area should be multiplied by the aeration percentage before selecting the flomixers.

This new "burner area" is then used to select the proper flomixer from Table I under the proper air pressure and fuel gas columns.

- CAPACITY BASIS.

Low mixture pressures. For the selection of flomixers to be used with multi-port, Pyroline or ribbon type burners where the maximum burner mixture pressure must be considerably less than shown in the flomixer table. Most ribbon pipe burners are figured for a mixture pressure of 0.5 mbar but the newer piloted types can handle mixtures up to 1.5 mbar. Operating against these lower mixture pressures, flomixer capacities are higher than listed in Table I.

Knowing the air pressure, type of gas and total kW to be supplied to one or more burners, the actual burner capacity is re-figured to get a new "selection capacity". Under the proper air pressure column of Table IV, select the desired operating mixture pressure. The figure to the right under column (J) is the "capacity multiplier" and is used as follows:

$$\frac{\text{Burner capacity}}{\text{Capacity multiplier "J"}} = \text{Selection capacity}$$

Corrections for air-gas ratio should be applied to the "selection capacity" before selecting the flomixer.

The "selection capacity", which is always smaller than the original "burner capacity", is used to select the flomixer under the proper air pressure and gas columns in the flomixer selection Table I.

THE FLOMIXER, BECAUSE OF ITS ADVANCED DESIGN, WILL GIVE SUPERIOR PERFORMANCE IF USED WITHIN THE LIMITS OF NORMAL OPERATION.

## POSSIBLE ASSEMBLED GROUPS

2301 - SERIES NO. 1



It is the basic series and includes:

- Mixer body
- Cone-shaped insert (screw inside the body)
- Air inlet and mixture outlet flanges
- Gas adjuster (series GA) welded to the mixer body through ESA-PYRONICS standard flanges.

2303 - SERIES NO. 3

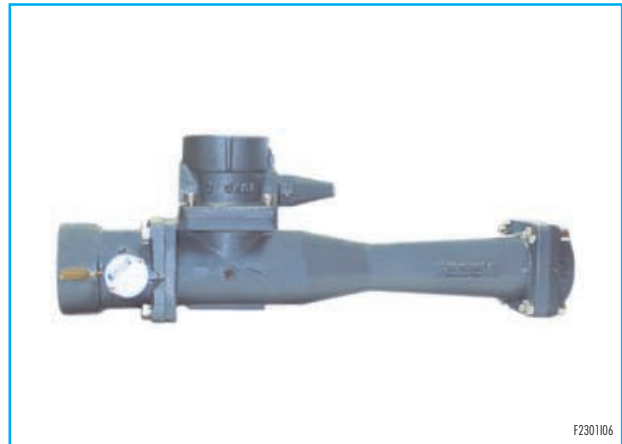

As compared to series no. 1, a straight air sleeve (standard ESA-PYRONICS) with pressure plug is placed between the mixer body and the air inlet flange.

2302 - SERIES NO. 2



As compared to series no. 1, the air inlet flange is replaced by a butterfly valve having one flanged side (standard ESA-PYRONICS) and one threaded side GAS.

2304 - SERIES NO. 4

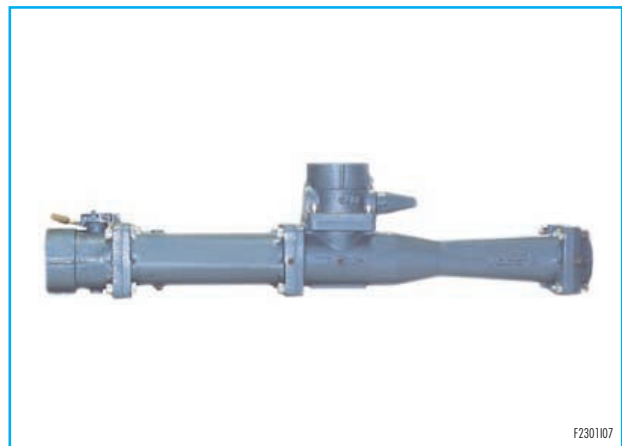

As compared to series no. 2, a straight air sleeve (standard ESA-PYRONICS) with pressure plug is placed between the mixer body and the butterfly valve.

For these 4 assemblies it is easy to deduct some data concerning the equipment from the abbreviations. In the catalog number of the flomixers the first group of figures stands for the diameter of the air inlet (the same of the mixture outlet) and the diameter of the gas inlet respectively (see below table).

After the first hyphen the number of the assembly of the flomixer comes. The type of working to be executed on the cone-shaped insert (according to the flow) is specified by the number after the second hyphen.

Catalog no.	88	108	1010	128	1210	1212	168	1610	1612	1616	2010	2012
Air inlet	G-1"	G-1 ¼"	G-1 ¼"	G-1 ½"	G-1 ½"	G-1 ½"	G-2"	G-2"	G-2"	G-2"	G-2 ½"	G-2 ½"
Gas inlet	G-¾"	G-¾"	G-1"	G-¾"	G-1"	G-1 ¼"	G-¾"	G-1"	G-1 ¼"	G-1 ½"	G-1"	G-1 ¼"
Mixture pipe	G-1"	G-1 ¼"	G-1 ¼"	G-1 ½"	G-1 ½"	G-1 ½"	G-2"	G-2"	G-2"	G-2"	G-2 ½"	G-2 ½"
Catalog no.	2016	2020	2410	2412	2416	2420	2424	3212	3216	3220	3224	3232
Air inlet	G-2 ½"	G-2 ½"	G-3"	G-3"	G-3"	G-3"	G-3"	G-4"	G-4"	G-4"	G-4"	G-4"
Gas inlet	G-1 ½"	G-2"	G-1"	G-1 ¼"	G-1 ½"	G-2"	G-2 ½"	G-1 ¼"	G-1 ½"	G-2"	G-2 ½"	G-3"
Mixture pipe	G-2 ½"	G-2 ½"	G-3"	G-3"	G-3"	G-3"	G-3"	G-4"	G-4"	G-4"	G-4"	G-4"

**Sold Out**

## FLOMIXER AND GAS PARTS ASSEMBLIES APPLICATIONS

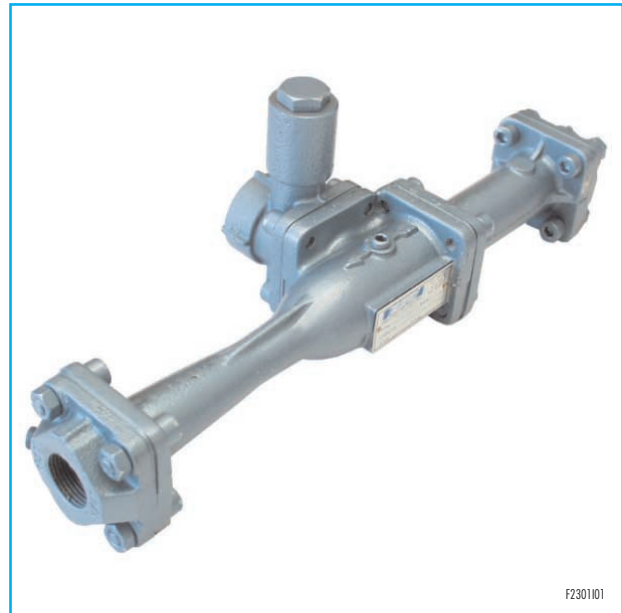
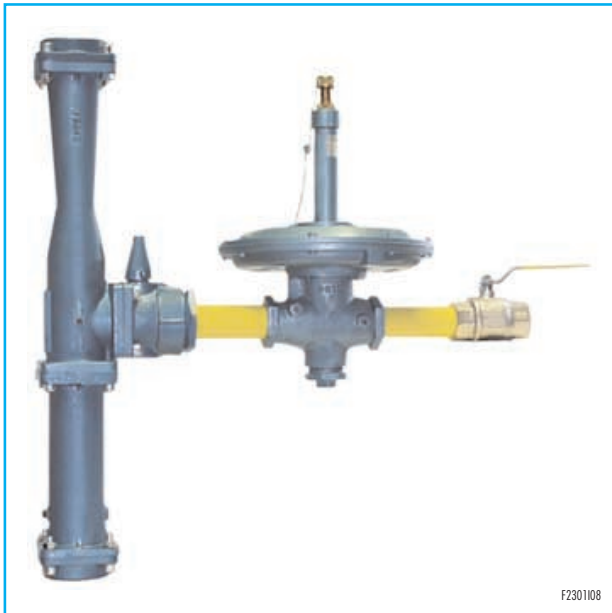

TABLE I - FLOMIXER SELECTION

Capacities in kW 17.8 to 71.2 mbar AIR			MINIMUM BURNER AREA (mm <sup>2</sup> )		FLOMIXER CATALOG NUMBERS FROM 17.8 TO 71.2 mbar AIR				CAPACITIES IN kW 89 TO 142.4 mbar AIR			MIN. BURNER AREA (mm <sup>2</sup> )		FLOMIXER CATALOG NUMBER 89 TO 142.4 mbar AIR			
17.8	35.6	53.4	71.2	0.9 COEF. OF DISCHARGE	MFD. GAS	MIXED GAS	NATURAL GAS	L.P. GAS	89	106.8	124.6	142.4	0.9 coef. of discharge	MFD. GAS	MIXED GAS	NATURAL GAS	L.P. GAS
MAX. MIXTURE PRESSURE IN mbar					MJ/Nm <sup>3</sup>	MJ/Nm <sup>3</sup>	MJ/Nm <sup>3</sup>	MJ/Nm <sup>3</sup>		MJ/Nm <sup>3</sup>	MAX. MIXTURE PRESSURE IN mbar	MJ/Nm <sup>3</sup>		MJ/Nm <sup>3</sup>	MJ/Nm <sup>3</sup>	MJ/Nm <sup>3</sup>	MJ/Nm <sup>3</sup>
7	10	13	15	69	88-8	88-8	88-8	88-8	16	17	20	21	69	88-8	88-8	88-8	88-8
9	14	16	19	94	88-9	88-9	88-9	88-9	21	23	26	27	94	88-9	88-9	88-9	88-9
12	16	20	23	108	88-10	88-10	88-10	88-10	27	29	31	33	108	88-10	88-10	88-10	88-10
15	21	26	29	131	88-11	88-11	88-11	88-11	33	36	38	42	131	88-11	88-11	88-11	88-11
17	24	30	35	157	88-12	88-12	88-12	88-12	40	43	47	50	157	88-12	88-12	88-12	88-12
21	29	35	41	177	108-13	108-13	108-13	108-13	47	50	55	58	177	108-13	108-13	108-13	108-13
24	34	42	49	214	108-14	108-14	108-14	108-14	55	59	64	69	214	108-14	108-14	108-14	108-14
27	38	47	55	244	128-15	128-15	128-15	128-15	60	66	72	77	244	128-15	128-15	128-15	128-15
31	44	55	63	279	128-16	128-16	128-16	128-16	70	77	84	90	279	128-16	128-16	128-16	128-16
35	50	60	70	301	128-17	128-17	128-17	128-17	79	86	92	100	301	128-17	128-17	128-17	128-17
40	56	69	79	352	128-18	128-18	128-18	128-18	88	97	103	112	352	128-18	128-18	128-18	128-18
44	62	77	88	394	128-19	128-19	128-19	128-19	98	108	116	124	394	128-19	128-19	128-19	128-19
49	70	85	98	437	128-20	128-20	128-20	128-20	110	120	130	140	437	128-20	128-20	128-20	128-20
53	76	93	107	479	160-21	160-21	160-21	160-21	120	131	142	151	479	160-21	160-21	160-21	160-21
58	83	101	117	526	160-22	160-22	160-22	160-22	130	143	156	165	526	160-22	160-22	160-22	160-22
64	91	112	129	575	160-23	160-23	160-23	160-23	143	158	170	184	575	160-23	160-23	160-23	160-23
70	100	122	141	628	160-24	160-24	160-24	160-24	157	172	186	199	628	160-24	160-24	160-24	160-24
77	108	131	152	677	160-25	160-25	160-25	160-25	170	187	202	215	677	160-25	160-25	160-25	160-25
83	116	142	164	735	160-26	160-26	160-26	160-26	184	201	216	231	735	160-26	160-26	160-26	160-26
88	126	153	177	794	160-27	160-27	160-27	160-27	198	216	235	250	794	160-27	160-27	160-27	160-27
95	135	165	191	852	2010-28	2010-28	2010-28	2010-28	213	233	252	270	852	2010-28	2010-28	2010-28	2010-28
102	145	178	205	916	2010-29	2010-29	2010-29	2010-29	229	252	271	290	916	2010-29	2010-29	2010-29	2010-29
110	156	191	220	981	2010-30	2010-30	2010-30	2010-30	247	270	290	310	981	2010-30	2010-30	2010-30	2010-30
117	165	203	235	1045	2010-31	2010-31	2010-31	2010-31	263	287	310	331	1045	2010-31	2010-31	2010-31	2010-31
124	176	215	249	1116	2010-32	2010-32	2010-32	2010-32	278	305	330	351	1116	2010-32	2010-32	2010-32	2010-32
141	199	243	281	1245	2410-34	2410-34	2410-34	2410-34	315	340	372	399	1245	2410-34	2410-34	2410-34	2410-34
158	224	274	316	1413	2410-36	2410-36	2410-36	2410-36	353	388	419	445	1413	2410-36	2410-36	2410-36	2410-36
176	249	305	351	1568	2410-38	2410-38	2410-38	2410-38	393	430	466	498	1568	2410-38	2410-38	2410-38	2410-38
197	277	338	391	1742	2410-40	2410-40	2410-40	2410-40	438	479	517	553	1742	2410-40	2410-40	2410-40	2410-40
215	305	373	430	1923	2410-42	2410-42	2410-42	2410-42	483	528	570	609	1923	2410-42	2410-42	2410-42	2410-42
236	334	409	472	2103	3220-44	3220-44	3220-44	3220-44	528	579	624	669	2103	3220-44	3220-44	3220-44	3220-44
259	366	450	519	2303	3220-46	3220-46	3220-46	3220-46	580	636	686	734	2303	3220-46	3220-46	3220-46	3220-46
281	397	488	563	2490	3220-48	3220-48	3220-48	3220-48	629	744	795	842	2490	3220-48	3220-48	3220-48	3220-48
305	429	526	608	2723	3220-50	3220-50	3220-50	3220-50	680	744	805	860	2723	3220-50	3220-50	3220-50	3220-50
330	466	571	659	2935	3220-52	3220-52	3220-52	3220-52	737	809	872	934	2935	3220-52	3220-52	3220-52	3220-52
355	501	614	709	3174	3220-54	3220-54	3220-54	3220-54	793	869	937	1002	3174	3220-54	3220-54	3220-54	3220-54
381	540	659	762	3413	3220-56	3220-56	3220-56	3220-56	851	934	1008	1076	3413	3220-56	3220-56	3220-56	3220-56
409	579	708	817	3658	3220-58	3220-58	3220-58	3220-58	914	1002	1081	1156	3658	3220-58	3220-58	3220-58	3220-58
436	616	756	873	3916	3220-60	3220-60	3220-60	3220-60	976	1070	1156	1235	3916	3220-60	3220-60	3220-60	3220-60
466	647	807	931	4181	3220-62	3220-62	3220-62	3220-62	1042	1143	1230	1319	4181	3220-62	3220-62	3220-62	3220-62
498	703	863	997	4458	3220-64	3220-64	3220-64	3220-64	1114	1221	1319	1409	4458	3220-64	3220-64	3220-64	3220-64

SHOULD BE EXPANDED TO 6" BEFORE CONNECTION TO A MANIFOLD EXCEPT IN SPECIAL CASES

Sold Out



**TABLE II - CORRECTION FACTORS FOR VARIOUS TYPES OF BURNERS**

Type of burner	Pepper box or multiple port burners AGF-KEMP-SELAS	Flame retaining, or piloted burners, blast types BRYANT-MAXON-N.A. ECLIPSE	Annular or single port type round or flat nosed tunnel burners BRYANT - N.A. - SURFAE NAT'L	Venturi type steel tunnel burners ECLIPSE
Approximate coefficient of discharge	0.45 ÷ 0.65	0.65 ÷ 0.75	0.75 ÷ 0.95	1.00 ÷ 1.20
Factor	2.0 ÷ 1.4	1.4 ÷ 1.2	1.2 ÷ 1.0	0.9 ÷ 0.75

**TABLE III - MIXTURE PRESSURE DEVELOPED BY FLOMIXERS AT VARIOUS AIR PRESSURES**

Air pressure mbar	8.8	17.6	26.4	35.1	44	52.7	61.5	70.3	79	87.9	96.7	105.5	114.2	123	131.8	140.6
Mixture pressure mbar	3.5	7.1	10.4	14	17.5	20.8	24.4	27.9	31.5	35	38.6	41.9	45.4	48.8	52.3	55.9

**TABLE IV - AREA AND CAPACITY MULTIPLIER**

AIR PRESSURE								Capacity multiplier (J)	Burner area multiplier (K)
17,8 mbar (A)	35,6 mbar (B)	53,4 mbar (C)	71,2 mbar (D)	89 mbar (E)	106,8 mbar (F)	124,6 mbar (G)	142,4 mbar (H)		
ORIGINAL MIXTURE PRESSURE mbar									
7	14	21	28	35	42	49	56	1,00	1,00
6,35	12,70	19,05	25,40	31,75	38,10	44,45	50,80	1,03	1,08
5,84	11,43	17,27	22,86	28,70	34,29	40,13	45,72	1,07	1,18
5,08	10,16	15,24	20,32	25,40	30,48	35,56	40,64	1,11	1,30
4,57	8,89	13,46	17,78	22,35	26,67	31,24	35,56	1,14	1,42
3,81	7,62	11,43	15,24	19,05	22,86	26,67	30,48	1,18	1,60
3,30	6,35	9,65	12,70	16,00	19,05	22,35	25,40	1,21	1,79
2,54	5,08	7,62	10,16	12,70	15,24	17,78	20,32	1,24	2,06
1,91	3,81	5,84	7,62	9,65	11,43	13,46	15,24	1,27	2,45
1,27	2,54	3,81	5,08	6,35	7,62	8,89	10,16	1,30	3,05
0,64	1,27	1,91	2,54	3,18	3,81	4,45	5,08	1,33	4,42
0,33	0,64	0,97	1,27	1,60	1,91	2,24	2,54	1,35	6,34
0,13	0,25	0,38	0,51	0,64	0,76	0,89	1,02	1,36	12,10
0,08	0,13	0,20	0,25	0,33	0,38	0,46	0,51	1,36	14,30

NEW MIXTURE PRESSURES mbar

DIMENSIONS

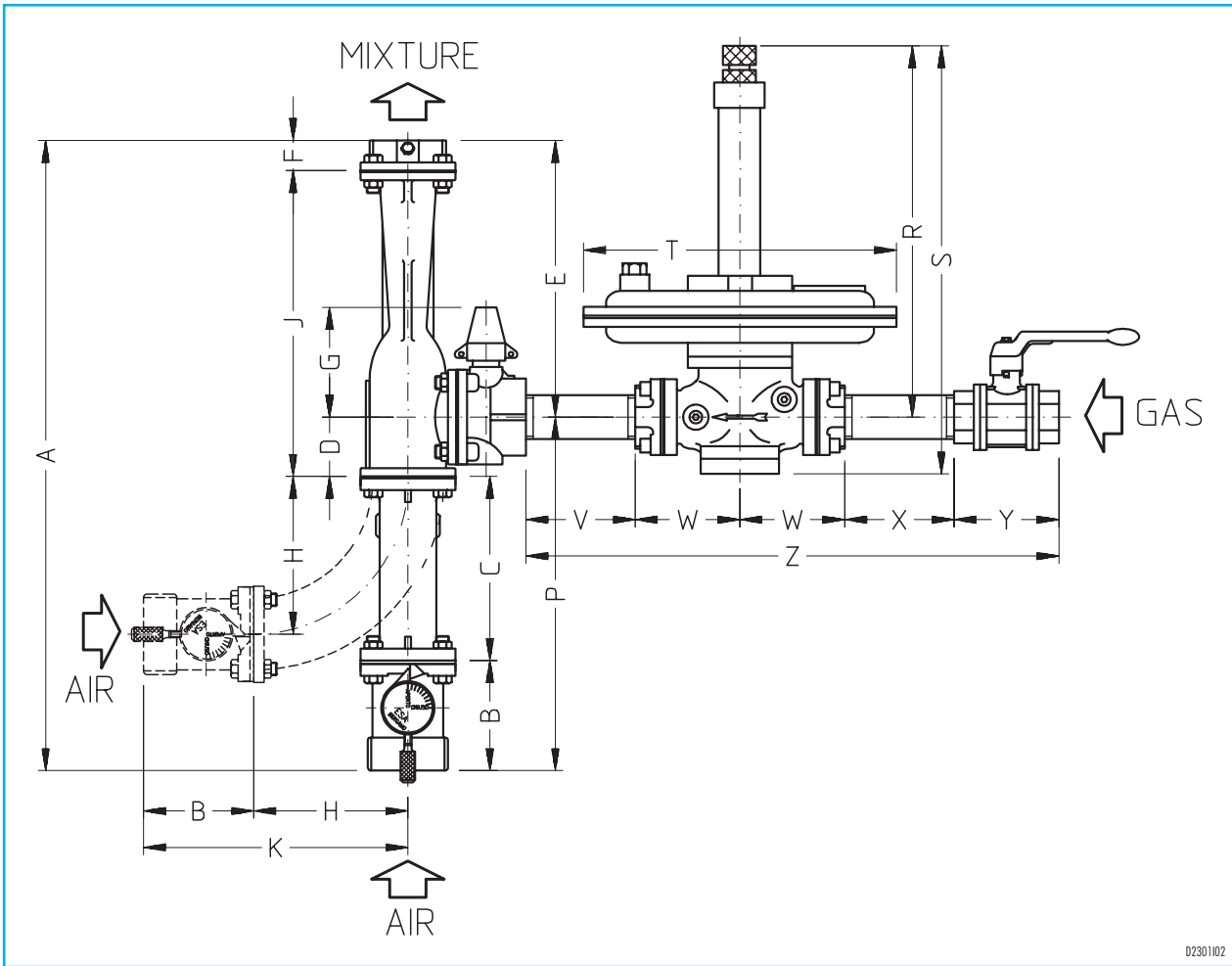

D230102

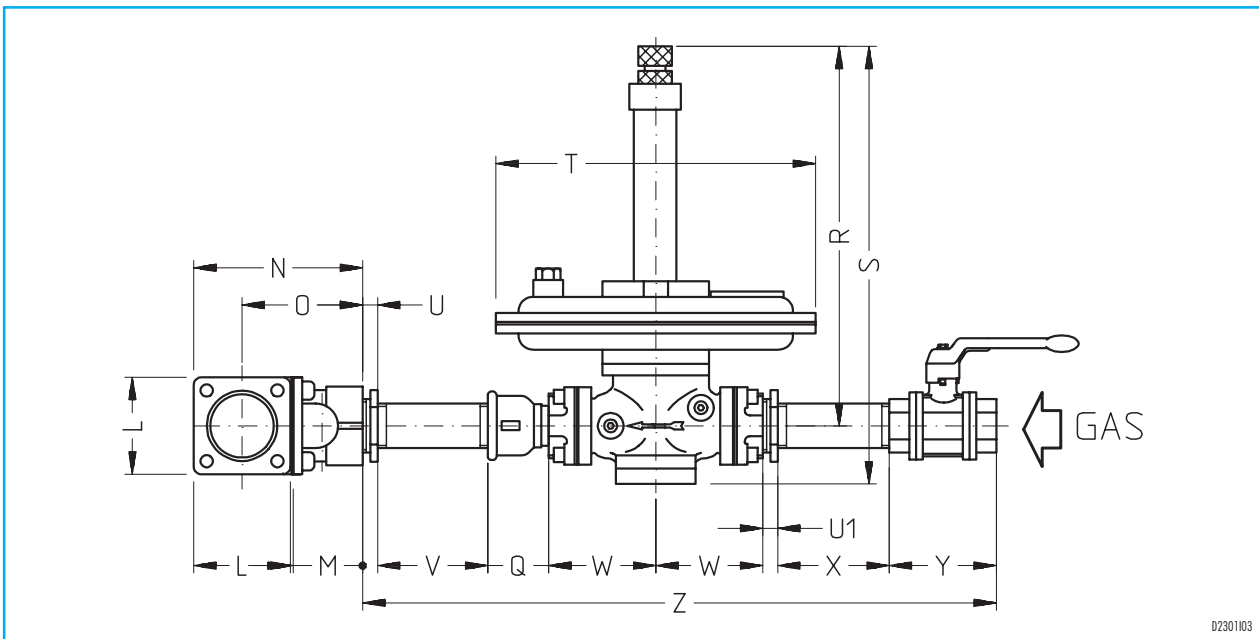

D230103

FLOMIXER & GAS PARTS ASSEMBLIES - DIMENSIONS

Catalog no.	FLOMIXER ASSEMBLY PIPE CONNECTIONS			A ±3 mm	B mm	C mm	D mm	E mm	F mm	G mm	H mm	J mm	K mm	L SQ. mm	M mm	N mm	O mm	P mm	Q mm	R Max. mm	S mm	T ∅ mm	U mm	UI mm	V mm	W mm	X ±3 mm	Y mm	Z ±10 mm
	∅ Air	∅ Gas	∅ Mixture																										
88	G-1"	G-3/4"	G-1"	419	86	108	36	189	19	86	63	206	149	59	43	108	79	230	—	222	273	210	—	120	48	120	80	416	
108	G-1 1/4"	G-3/4"	G-1 1/4"	565	89	152	49	275	32	92	103	292	192	76	59	138	100	290	—	222	273	210	10	120	48	120	80	426	
1010	G-1 1/4"	G-1"	G-1 1/4"	565	89	152	49	275	32	92	103	292	192	76	59	138	100	290	—	241	289	248	10	120	60	120	90	460	
128	G-1 1/2"	G-3/4"	G-1 1/2"	565	89	152	49	275	32	92	103	292	192	76	59	138	100	290	—	222	273	210	10	120	48	120	80	426	
1210	G-1 1/2"	G-1"	G-1 1/2"	565	89	152	49	275	32	92	103	292	192	76	59	138	100	290	—	241	298	248	10	120	60	120	90	460	
1212	G-1 1/2"	G-1 1/4"	G-1 1/2"	565	89	152	49	275	32	92	103	292	192	76	59	138	100	290	—	346	429	298	—	120	78	120	110	506	
168	G-2"	G-3/4"	G-2"	694	94	235	60	305	32	108	141	333	235	87	70	165	122	389	40	222	273	210	10	120	48	120	80	466	
1610	G-2"	G-1"	G-2"	694	94	235	60	305	32	108	141	333	235	87	70	165	122	389	—	241	296	248	10	120	60	120	90	460	
1612	G-2"	G-1 1/4"	G-2"	694	94	235	60	305	32	108	141	333	235	87	70	165	122	389	—	346	429	298	10	120	78	120	110	516	
1616	G-2"	G-1 1/2"	G-2"	694	94	235	60	305	32	108	141	333	235	87	70	165	122	389	—	346	429	298	10	120	78	120	120	526	
2010	G-2 1/2"	G-1"	G-2 1/2"	786	106	240	65	375	32	117	168	408	275	102	86	197	146	411	40	241	298	248	15	120	60	120	90	505	
2012	G-2 1/2"	G-1 1/4"	G-2 1/2"	786	106	240	65	375	32	117	168	408	275	102	86	197	146	411	—	346	429	298	15	110	78	110	110	516	
2016	G-2 1/2"	G-1 1/2"	G-2 1/2"	786	106	240	65	375	32	117	168	408	275	102	86	197	146	411	—	346	429	298	15	110	78	110	120	511	
2020	G-2 1/2"	G-2"	G-2 1/2"	786	106	240	65	375	32	117	168	408	275	102	86	197	146	411	—	410	502	356	—	110	111	110	140	582	
2410	G-3"	G-1"	G-3"	922	111	290	84	437	38	152	206	483	317	111	105	224	168	486	—	241	298	248	15	110	60	110	90	445	
2412	G-3"	G-1 1/4"	G-3"	922	111	290	84	437	38	152	206	483	317	111	105	224	168	486	—	346	429	298	15	110	78	110	110	516	
2416	G-3"	G-1 1/2"	G-3"	922	111	290	84	437	38	152	206	483	317	111	105	224	168	486	—	346	429	298	15	110	78	110	120	511	
2420	G-3"	G-2"	G-3"	922	111	290	84	437	38	152	206	483	317	111	105	224	168	486	—	410	502	356	—	110	111	110	140	582	
2424	G-3"	G-2 1/2"	G-3"	922	111	290	84	437	38	152	206	483	317	111	105	224	168	486	—	410	502	356	15	110	111	110	150	607	
3212	G-4"	G-1 1/4"	G-4"	1091	122	343	102	524	41	175	252	584	375	152	125	286	210	567	—	346	429	298	—	110	78	110	110	486	
3216	G-4"	G-1 1/2"	G-4"	1091	122	343	102	524	41	175	252	584	375	152	125	286	210	567	—	346	429	298	20	110	78	110	120	516	
3220	G-4"	G-2"	G-4"	1091	122	343	102	524	41	175	252	584	375	152	125	286	210	567	—	410	502	356	20	110	111	110	140	622	
3224	G-4"	G-2 1/2"	G-4"	1091	122	343	102	524	41	175	252	584	375	152	125	286	210	567	—	410	502	356	20	110	111	110	150	612	
3232	G-4"	G-3"	G-4"	1091	122	343	102	524	41	175	252	584	375	152	125	286	210	567	—	438	552	356	20	110	146	110	175	707	

Sold Out



NOTE: Based on the company's policy aimed at a continuous improvement on product quality, ESA-PYRONICS reserves the right to bring changes to the technical characteristics of this device without previous notice. Our catalog updated to the latest version is available on our web site [www.esapyronics.com](http://www.esapyronics.com) and it is possible to download modified documents

WARNING: When operating, this combustion system can be dangerous and cause harm to persons or damage to equipment. Every burner must be provided with a protection device that monitors the combustion. The installation, adjustment and maintenance operations should only be performed by trained and qualified personnel.