

# MICROPROCESSOR-OPERATED BURNER CONTROL DEVICE

## ESA ESTRO SERIES

### FEATURES

- Supply voltage: 115 or 230 V +10-15%
- Frequency: 45÷65 Hz
- Power consumption (without outlets): 4 VA max
- Operating temperature: 0 ÷ 60 °C
- Storage temperature: -20 ÷ 80 °C
- Maximum relative humidity: 75 %
- Protection class (when wiring, use adequate connectors): IP54
- Mounting position: any
- Load protection fuse: 3,15 A
- Device protection fuse: 1 A
- Maximum output capacity: 3 A @ 230 V  $\cos\phi = 0.5$
- Probe voltage: 300 V ac
- Minimum ionization current: 3  $\mu$ A
- Flame current limitation: 3,2 mA
- Flame signal display: 0 ÷ 90  $\mu$ A
- Prepurge time \*: 0 ÷ 255 s
- First safety time: 1 ÷ 25 s
- Main burner stabilization time: 1 ÷ 25 s
- Reaction time: 1 ÷ 20 s
- Post-purge time \*: 0÷255 s
- Auto shutoff (can be inhibited): within 24 hours
- Optional inputs voltage: 24, 48, 115, 230 V ac/dc
- Optional inputs absorption: max 5mA  
(thermostat, pressure switch, limit switch)
- Lock/reset input absorption: max 5mA
- Filter for lock/reset input: RC 100 $\Omega$  - 0.47  $\mu$ F - 250 V ac
- Casing: thermosetting
- Dimensions: 200×120×93 mm
- Mass: 1.200 g
- Flame controlling device: rod or UV-2 phototube (ESA)
- Insulation among probe conductors: > 50 M $\Omega$   
(double-insulation or double-protection cables)
- Rod or UV tube probe line length: < 30 m
- Unirod probe line length with TAR-10 transformer: 2 m max

\* WHEN THE EXP-1 EXPANSION CARD IS NOT PROVIDED, THESE VALUES MUST BE CONSIDERED AS IDLE TIMES



F7013101

CE 0694BM1678

SR<sup>US</sup> 1264559

FM  
APPROVED

3017653

### APPROVALS

- EN298 certificate for gas burners - 0063BM1678
- EN230 certificate for gas burners - 0063BM1678
- UL1998 certificate for burners - 1264559
- FM Approvals n° 3017653

### APPLICATIONS

- Flame control for one or two-stage, discontinuous gas or oil burners
- Flame control for packaged burners managing a complete ignition cycle (blower, air damper, air pressure switch)
- Flame control suitable for flame detection by means of rod, unirod and UV tube (also in combination with each other)
- Flame control with serial interface for remote control in multi-burner systems (tunnel type furnaces)



**Headquarters**  
Esa S.r.l.  
Via E. Fermi 40 I-24035 Curno (BG) - Italy  
Tel. +39.035.6227411 - Fax +39.035.6227499  
esa@esacombustion.it - www.esapyronics.com

**International Sales**  
Pyronics International S.A./N.V.  
Zoning Ind., 4ème rue B-6040 Jumet - Belgium  
Tel +32.71.256970 - Fax +32.71.256979  
marketing@pyronics.be

## DESCRIPTION

ESA ESTRO is a microprocessor-operated flame controlling device equipped with inputs and outputs for the ignition and control of industrial burners. There exist three different versions of the same device:

- ESTRO B: device for two-stage burners (pilot and main gas valves). Remote control via electric and serial signals with powered output when the burner is on.
- ESTRO C: device for one-stage burners (only one gas valve). Remote control via electric and serial signals with normally open output when the burner is on.

- ESTRO Q: device for one-stage burners (only one gas valve). Remote control via serial signals.

An EXP-1 expansion card may be applied to any of the three versions to control a burner equipped with air damper, blower, and pressure switch (packaged burner).

On the front panel there is a lock/reset button, a cycle display, a flame signal indicator and two leds to send and receive the infrared signal. The device is supplied in a strong thermosetting casing equipped with holes for the cable outputs which may be cabled in advance if required and for the TAR-10 ignition transformer.

## REAR PANEL

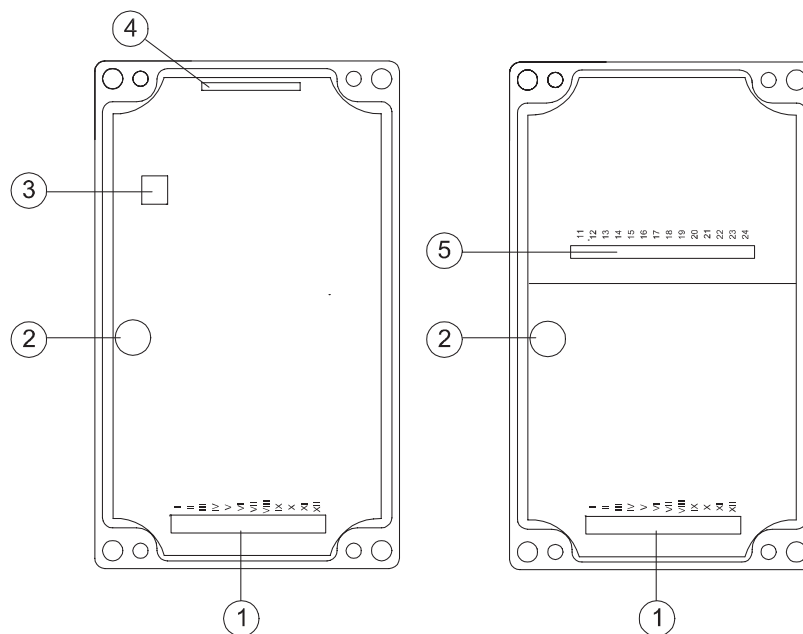

ESTRO - STANDARD

ESTRO - WITH EXP-1 CARD

Item	Description
1	Main terminal block for connection
2	Fuse for loads
3	Terminal block for serial communication
4	Expansion board EXP-1 inlet
5	Terminal block for EXP-1 expansion card

D7013106

## CONNECTIONS ESTRO-B

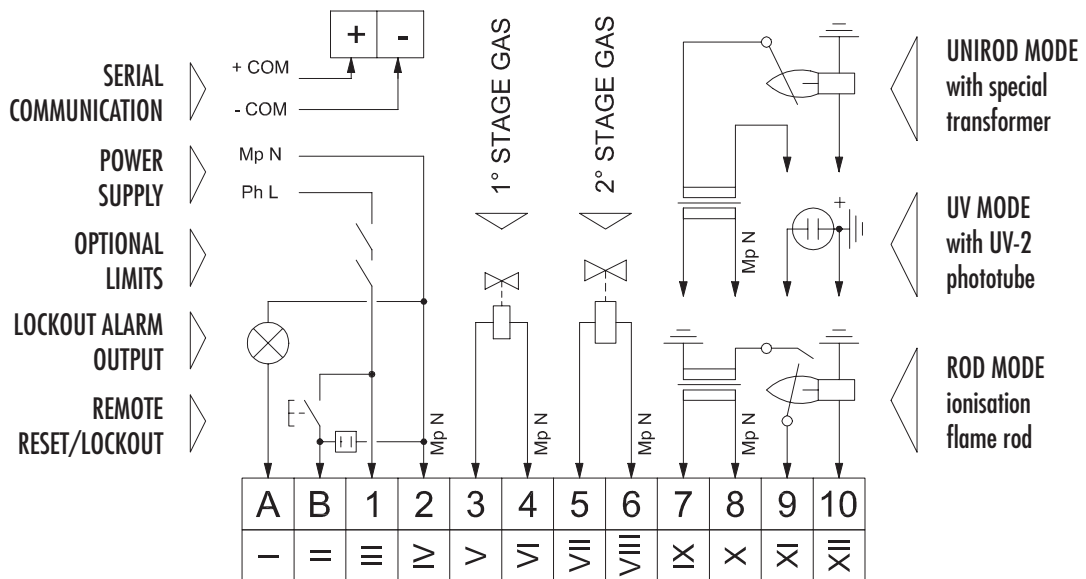

Item	Description	Item	Description
A	Lockout signal output	6	2° stage gas valve neutral
B	Remote reset/lockout input	7	Ignition transformer phase
1	Power supply phase	8	Ignition transformer neutral
2	Power supply neutral	9	Rod or phototube negative end
3	1° stage gas valve phase	10	Protection ground, UV phototube positive end or burner frame
4	1° stage gas valve neutral	+	Communication input positive end
5	2° stage gas valve phase	-	Communication input negative end

D7013102

## CONNECTIONS ESTRO-C

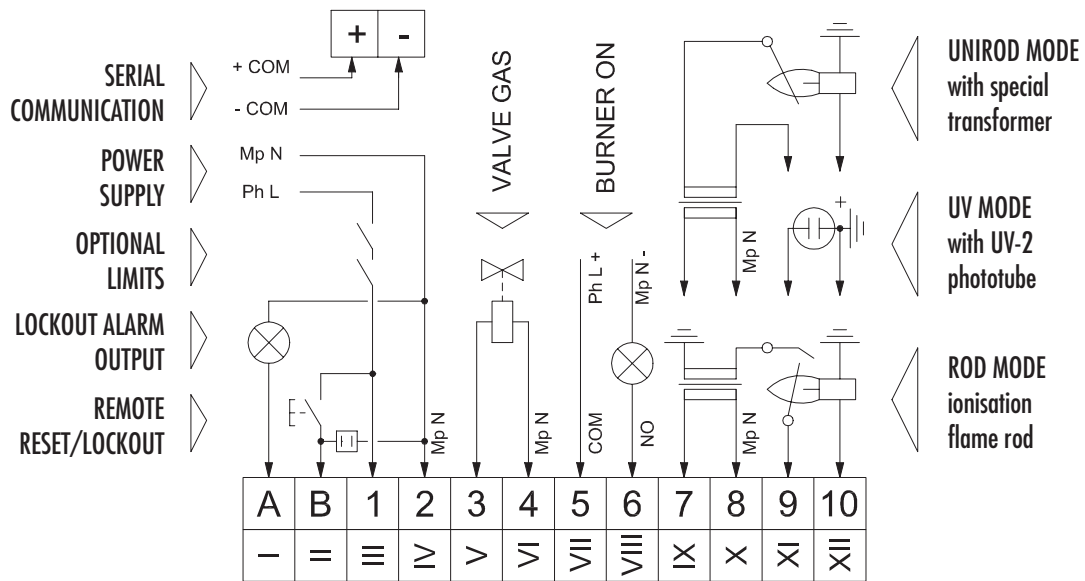

Item	Description	Item	Description
A	Lockout signal output	6	Burner on output (NO)
B	Remote reset/lockout input	7	Ignition transformer phase
1	Power supply phase	8	Ignition transformer neutral
2	Power supply neutral	9	Rod or phototube negative end
3	Gas valve phase	10	Protection ground, UV phototube positive end or burner frame
4	Gas valve neutral	+	Communication input positive end
5	Burner on output (Com)	-	Communication input negative end

D7013103

## CONNECTIONS ESTRO-Q

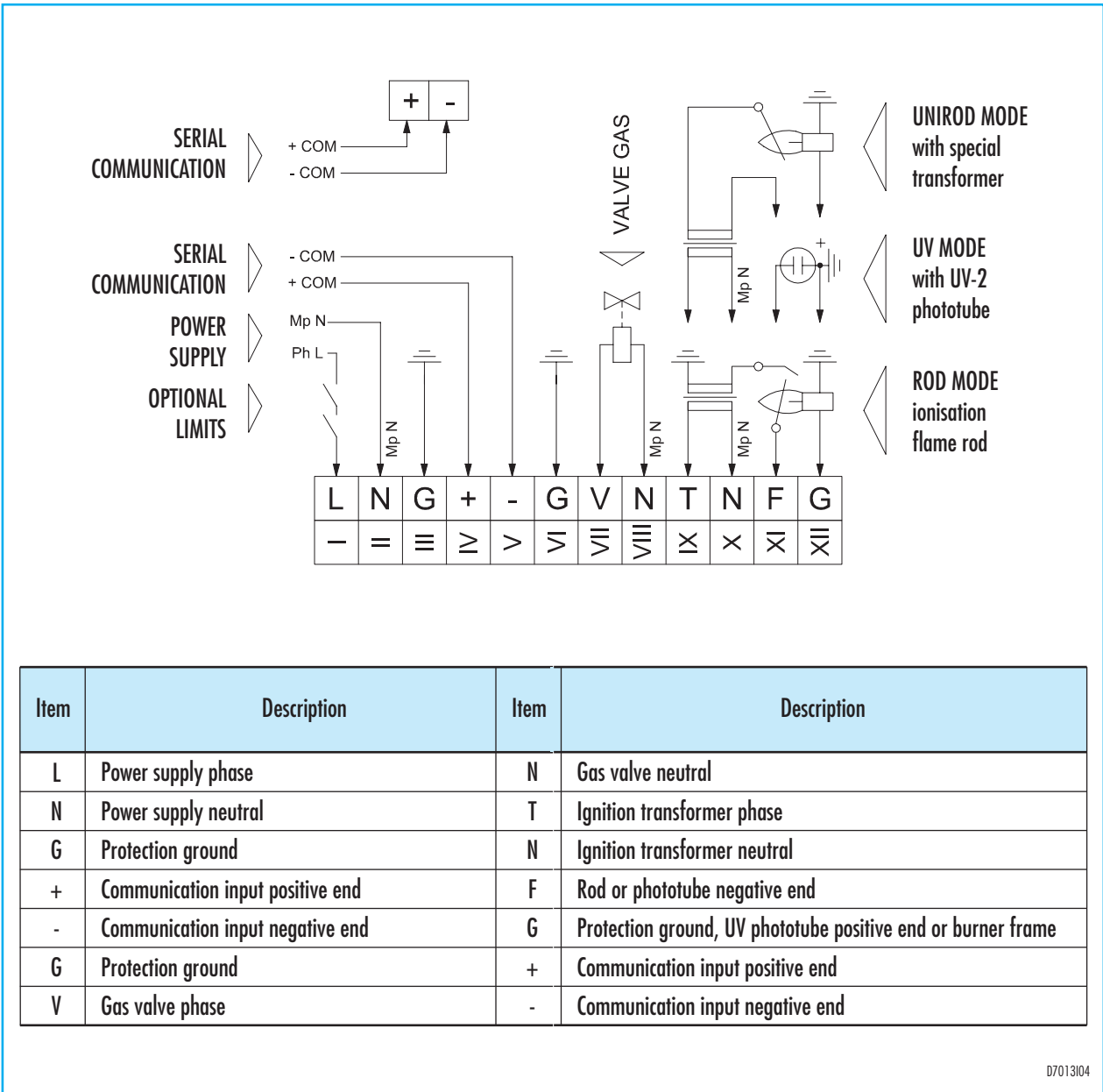

D7013104

CONNECTIONS EXPANSION CARD EXP-1

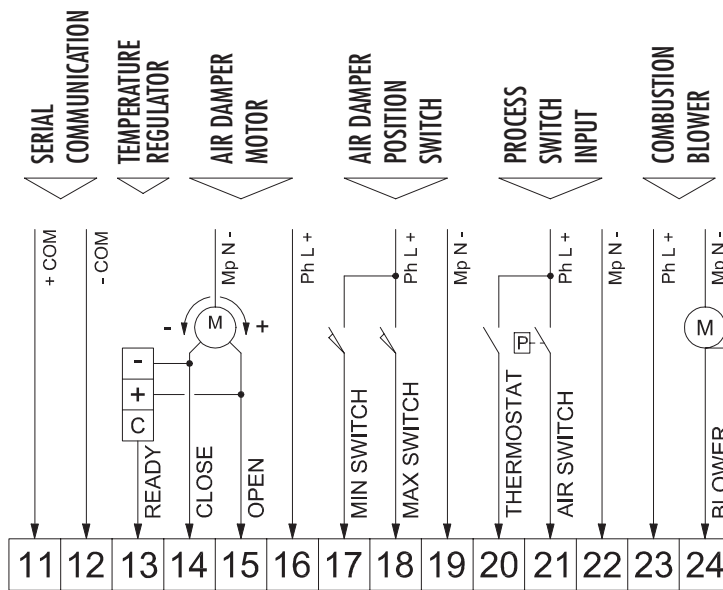

Item	Description	Item	Description
11	Communication input positive end	18	Damper hi-fire switch output
12	Communication input negative end	19	Damper limit switch outputs common
13	Thermoregulation enabling output	20	Thermostat start/stop input
14	Air damper closing output	21	Air pressure switch input
15	Air damper opening output	22	Process limit inputs common
16	Air damper motor power supply	23	Blower motor power supply
17	Damper lo-fire switch output	24	Blower motor output

D7013105

## DIAGRAM OF TIMES

The behaviour of the ESTRO device may differ depending on the programmed parameters. Below is the description of two types of typical behaviours, one for the basic and one for the EXP-1 expansion card versions

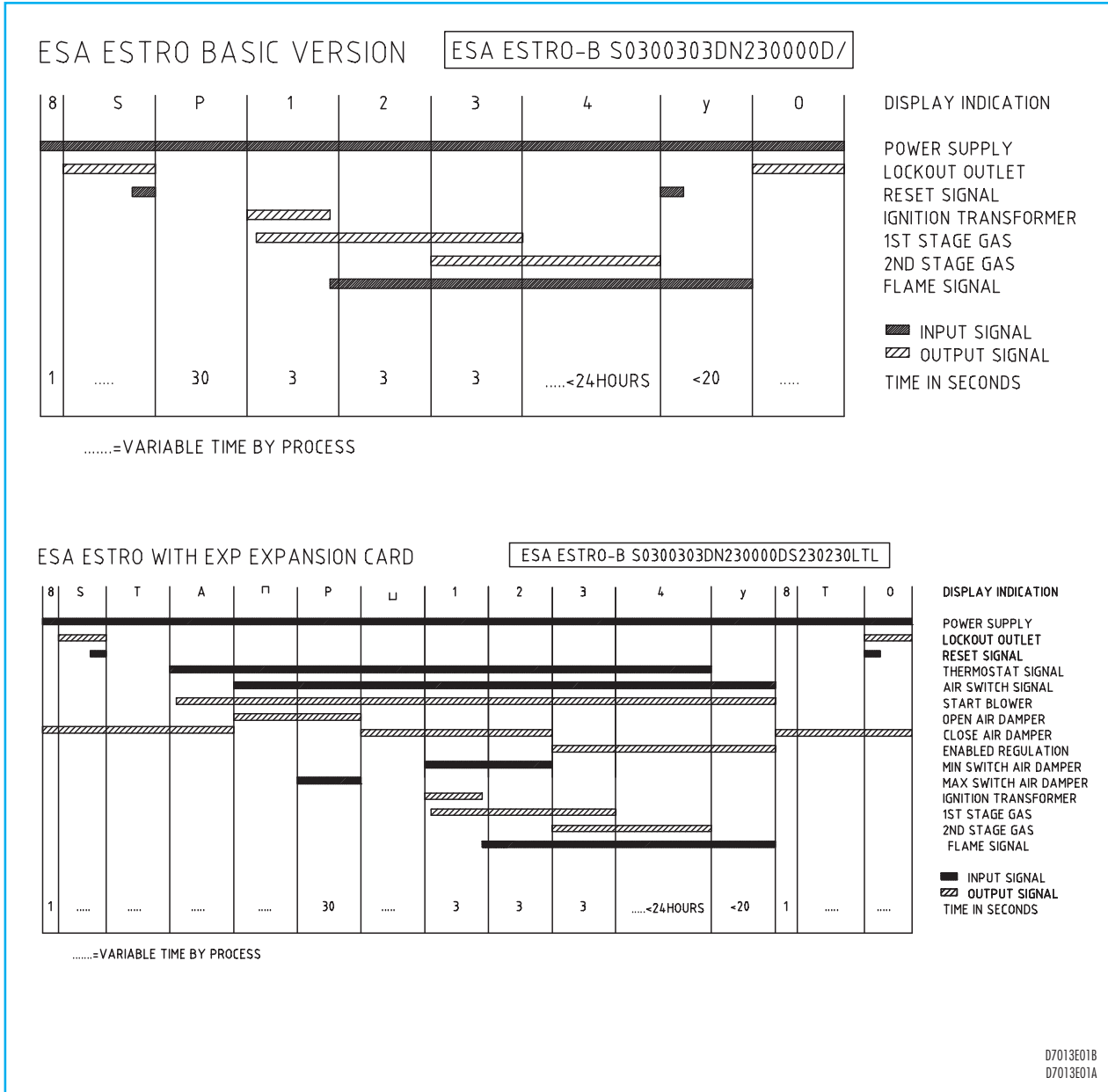

In case of ESTRO-C, ESTRO-Q and ESTRO-B with intermittent 1<sup>st</sup> stage, the operating condition is represented by phase No "3". This condition must not last over 24 hours.

Description	Max safety time	Max flame failure response	Note
Gas burner (EN298)	according to application and standard EN746	1 s	Resparking
		according to application and standard EN746	Without resparking
Oil burner with gas fired pilot burner	5 s	5 s	All application - two oil valves in series must be applied
Oil burner fuel throughput < 30 kg/h	10 s	1 s	Resparking
	10 s	10 s	Without resparking - Prepurge > 5 s
	20 s	20 s	Without resparking - Prepurge < 5 s
Oil burner fuel throughput > 30 kg/h	5 s	1 s	Without resparking (Resparking may not be applied)

## INSTALLATION

- Avoid placing the equipment near intense magnetic or electric fields, and in such conditions as to be exposed to direct heat or products resulting from combustion, such as corrosive liquids, solvents or gases.
- The equipment must be installed by skilled staff, in compliance with the regulations in force at the time and in the place of installation.
- A minimum protection class of IP40 must be always guaranteed when installing the device on the casing.
- This device is intended for permanent connection to the electric installation and should never be fitted with a reversible mains plug. Check correct connections after installation. Reversal of the live/neutral connection may impair the safety of the unit.
- Check the supply voltage, frequency and capacity are correct. Verify that the connected outputs do not exceed the maximum contacts capacity.
- Study all technical information and respect it, in particular the phase-neutral polarity, when making electric connections. The type of conductors and their location must be suitable for their application.
- The flame signal cables must be separated from the other conductors. No multipolar cables are hence allowed. No shielded cables are allowed, either.
- Detection probes and connectors (if any) must be isolated and out of reach. The casing must be adequately protected; only skilled personnel should be allowed to touch or work on it. Suitable warnings should be placed next to the probes, if necessary.
- Always connect the protection ground to the correct terminals and to any metallic frames using conductors of suitable section.
- When using the remote reset input, connect the RC filter.
- In multiple-burner applications, the parallel connections of the outputs of several devices are not allowed. If the system is equipped with a serial interface connection, please stick to the special instructions provided for using the remote-controlled functions.
- In multiple-burner systems with burners installed in the same combustion chamber, where a shutoff every 24 hours cannot be enabled, the control system must order the burners to shutoff.
- The communication line must be separated from the supply line, engine control (inverters) and network voltage. NEITHER MULTIPOLAR NOR SHIELDED cables must be used.
- In communication lines, unipolar cables for electric use, featuring a section of over 0.5 mm<sup>2</sup> must be used. An alternative to unipolar cables is represented by busway systems, bearing in mind that the length between the busway and the device should not exceed 1 m, both for the communication and the supply lines.
- A protection fuse on the active ECS line should be installed to avoid prolonged short-circuits from damaging the card. In case use a rapid blow fuse (1 A).
- Before carrying out any operation, ensure the power supply line and any other connections are disconnected, label all wires prior to disconnecting.
- The thermostat input of the expansion card is an adjustment control not a safety control.
- Input cables to EXP-1 expansion card must be rolled up at least once around ferrite supplied.

## STATUS DISPLAY

The display gives, at any time, a clear indication about the working conditions of the burner. A fixed-luminous code corresponds to normal operating conditions whereas a blinking code means there is

some lockout condition or fail requiring the intervention of an operator.

### ESTRO - STANDARD VERSION

Below is a standard sequence of an equipment without expansion card. In this case, the equipment is powered after controlling all the limits and safety devices of the system, and after the prepurge stage has taken place.

DISPLAY	INDICATION	DESCRIPTION
8	FIXED	Self-diagnosis phase; the equipment controls the efficiency of its components. It shows every time the equipment is powered or when the burner is re-started (it lasts 1 s).
0	BLINKING	Manual lockout. The equipment waits for the operator to reset it via the local, remot or serial button.
5	BLINKING	Awaiting phase when a standby mode has been programmed. The equipment waits for the operator to reset it via the local, remot or serial button.
8	FIXED	Self-diagnosis phase; the equipment controls the efficiency of its components. It shows every time the equipment is powered or when the burner is re-started (it lasts 1 s).
P	FIXED	Awaiting phase or prepurge time (it lasts from 0 to 255 s).
d	BLINKING	Lockout due to flame detection during the prepurge cycle. It may depend on the detection system (fail in the probe) or gas blow-by from the gas safety valve. This type of lockout may also occur when switching the burner off.
1	FIXED	Ignition phase of the 1 <sup>st</sup> stage of the burner (or 1 <sup>st</sup> safety time). The equipment starts the ignition transformer, the gas safety valve of the 1 <sup>st</sup> stage and verifies the flame formation (it lasts from 0 to 25 s).
U	BLINKING	Lockout due to flame failure during the 1 <sup>st</sup> safety time. It may be caused by the gas safety valve ignition system or by some fail in the transformers, by the gas flow regulation or the detection system.
2	FIXED	Phase when the flame stability of the 1 <sup>st</sup> stage of the burner is verified. The device verifies the efficiency of the flame probe (it lasts 3 s).
3	FIXED	Ignition phase of the 2 <sup>nd</sup> stage of the burner (or 2 <sup>nd</sup> safety time). The equipment enables the output of the 2 <sup>nd</sup> stage gas safety valve and confirms the 1 <sup>st</sup> stage gas output (it lasts from 1 to 25 s). This condition also concerns the intermittent mode.
4	FIXED	Up-keeping phase of the 2 <sup>nd</sup> stage of the burner. The equipment intercepts the output of the 1 <sup>st</sup> stage gas safety valve. This condition only concerns the interrupted mode, therefore it only concerns the ESTRO-B version.

DISPLAY	INDICATION	DESCRIPTION
F	BLINKING	Lockout due flame loss during standard working conditions. It may be due to the air or gas flow regulation or detection system.
Y	FIXED	Phase when the detection system is verified. The equipment verifies that the flame extinguishes by 20 seconds since the burner has been switched off, otherwise a lockout (C) follows.
8.	FIXED	Postpurge phase after the burner has been switched off. During this phase no operation can be performed (it lasts from 0 to 255 s).
H	FIXED	Awaiting phase occurring if the equipment has received a serial halt command. The equipment intercepts all the outputs while the burner is still off.
C	BLINKING	Lockout due to the prolonged lack of serial drives from the remote supervisor. The equipment intercepts all the outputs while the burner is still off when this lack exceeds the "com time out" (from 0 to 2040s)

### ESTRO WITH EXP-1 EXPANSION CARD

Should the equipment be equipped with the expansion card for the supervision of a packaged burner, the following phases will take place:

DISPLAY	INDICATION	DESCRIPTION
8	FIXED	Self-diagnosis phase; the equipment controls the efficiency of its components. It shows every time the equipment is powered or when the burner is re-started (it lasts 1 s).
0	BLINKING	Manual lockout. The equipment waits for the operator to reset it via the local, remote or serial button.
L	FIXED	Awaiting phase for the remote thermostat signal for regulation shutoff. The equipment forces the air damper to shut.
P	BLINKING	Lockout due to the presence of the air pressure switch signal before starting the combustion blower. This type of lockout is due to incorrect cabling or fail in the pressure switch.
R	FIXED	Awaiting phase for the air pressure switch signal after starting the combustion blower.
8	FIXED	Self-diagnosis phase; the equipment controls the efficiency of its components. It shows every time the equipment is powered or when the burner is re-started (it lasts 1 s).
n	FIXED	Phase when the air damper is open while waiting for the damper to reach the hi-fire position.
P	FIXED	Awaiting phase or prepurge time (it lasts from 0 to 255 s).

DISPLAY	INDICATION	DESCRIPTION
U	FIXED	Phase when the air damper is closed while waiting for the damper to reach the lo-fire position.
1	FIXED	Ignition phase of the 1 <sup>st</sup> stage of the burner (or 1 <sup>st</sup> safety time). The equipment starts the ignition transformer, the gas safety valve of the 1 <sup>st</sup> stage and verifies the flame formation (it lasts from 0 to 25 s).
2	FIXED	Phase when the flame stability of the 1 <sup>st</sup> stage of the burner is verified. The device verifies the efficiency of the flame probe (it lasts 3 s).
3	FIXED	Ignition phase of the 2 <sup>nd</sup> stage of the burner (or 2 <sup>nd</sup> safety time). The equipment enables the output of the 2 <sup>nd</sup> stage gas safety valve and confirms the 1 <sup>st</sup> stage gas output (it lasts from 1 to 25 s). This condition also concerns the intermittent mode.
4	FIXED	Up-keeping phase of the 2 <sup>nd</sup> stage of the burner. The equipment intercepts the output of the 1 <sup>st</sup> stage gas safety valve. This condition only concerns the interrupted mode, therefore it only concerns the ESTRO-B version.
A	BLINKING	Lockout due to the lack of air pressure switch signal during standard working conditions. This type of lockout is connected to the air flow (clog filters, etc.)

## FAILURE MESSAGES

During standard working conditions, indications concerning failures within or outside the device may be displayed, for instance:

DISPLAY	INDICATION	DESCRIPTION
L	BLINKING	Lockout due to some power cut at the outputs of the equipment. The causes may relate to the connected electric devices (gas safety valves, ignition transformer or safety fuse).
7	BLINKING	Lockout due to some fail in the inside flame amplifier: if after one resetting attempt the problem arises again, the equipment must be returned to the producer.
0	BLINKING	Lockout due to the inside detection circuit: if after one resetting attempt the problem arises again, the equipment must be returned to the producer.
b	BLINKING	Lockout due to a malfunctioning within the device of the input from thermostat: if after one reset attempt the problem arises again, the equipment must be returned to the producer.
E	BLINKING	Lockout due to a mistake while reading the memory: if after one resetting attempt the problem arises again, the equipment must be returned to the producer.
2	BLINKING	Lockout due to the fact that the air damper cannot reach the lo-fire position by 150 seconds since the end of the purge time. The causes may be related to the connection or positioning of the air damper limit switch.

DISPLAY	INDICATION	DESCRIPTION
6	BLINKING	Lockout due to some shortcircuit at the outputs. if after one resetting attempt the problem arises again, the equipment must be returned to the producer.
7	BLINKING	Lockout due to the presence of the hi-fire signal even though the air damper is in a lo-fire position. The causes may be related to the connection or positioning of the air damper limit switch.
4	BLINKING	Lockout due to the presence of the lo-fire signal even though the air damper is in a hi-fire position. The causes may be related to the connection or positioning of the air damper limit switch.
9	FIXED	Malfunctioning in the either local or remot reset button which seems to be stuck to the pressed- button position. It is connected to the remot connection (no filter) or front button. In order to detect the alarm causing the lockout, cut the electric supply for a few seconds and then reset the equipment. If after one resetting attempt the problem arises again, the equipment must be returned to the producer.
≡	FIXED	Malfunctioning due to memory corruption. In order to detect the alarm causing the lockout, cut the electric supply for a few seconds and then reset the equipment. If after one resetting attempt the problem arises again, the equipment must be returned to the producer.
0	FIXED	Malfunctioning due to shortcircuited safety relay. In order to detect the alarm causing the lockout, cut the electric supply for a few seconds and then reset the equipment. If after one resetting attempt the problem arises again, the equipment must be returned to the producer.
0	FIXED	Malfunctioning due to the shortcircuited microprocessor outputs. In order to detect the alarm causing the lockout, cut the electric supply for a few seconds and then reset the equipment. If after one resetting attempt the problem arises again, the equipment must be returned to the producer.
U	FIXED	Malfunctioning due to some gap in the program performance. In order to detect the alarm causing the lockout, cut the electric supply for a few seconds and then reset the equipment. If after one resetting attempt the problem arises again, the equipment must be returned to the producer.

## CONFIGURATION

During the configuration the following indications will be displayed:

DISPLAY	INDICATION	DESCRIPTION
—	FIXED	The equipment is going to be programmed from the serial input; during this phase no operation can be performed.
!!	FIXED	The equipment is going to be programmed from the infrared input; during this phase no operation can be performed

## CONFIGURATION PARAMETERS

The configuration defines the operating modes. The equipment is programmed according to the application. Some parameters are factory-settled and then "locked" to comply with the applicable standards, whereas other parameters may be modified by the user via special programming devices. Any setting which is modified by the user and then locked can no longer be modified but by the producer. Programming is only possible if the flame controlling

device is in manual lockout (☐). The serial address is programmed by means of the portable device, whereas special software allows to set all parameters. You should remember that while programming one equipment via the serial line the device **MUST BE DISCONNECTED** from the field network and be connected directly to the interface card.

Special software allows to modify the following parameters:

PARAMETER	ACCESS	DESCRIPTION
Segment	YES	it identifies the area or group the device belongs to, for the purpose of the serial communication. All alphanumeric characters are considered as valid identifiers (0-9 and A-Z, capital letters).
Node	YES	it identifies the device as a unit within a given group or area, for the purpose of the serial communication. All alphanumeric characters are considered as valid identifiers (0-9 and A-Z, capital letters).
Prepurge	YES	Combustion chamber prepurge time, that can be set 0÷255 s. If it is set to 0 s, lockout ☐ is not displayed
1 <sup>st</sup> safety time	NO	1 <sup>st</sup> safety time to be set: range 1÷25 s.
2 <sup>nd</sup> stage gas time	NO	Main burner flame stabilization time to be set: range 1÷25 s.
Reaction time	NO	Time elapsing from the extinction of flame to gas interception. It must be programmed in compliance with the regulations concerning the specific application. It can be set from 1 to 20 s.
Com timeout	YES	Time of serial communication alarm, can be set by steps of 8" s up to 2040 s. It must be set to 0 if no serial communication is used.
Postpurge	YES	Combustion chamber postpurge time, which can be set from 0 to 255 s.
Power-on	YES	Behaviour on supplying power. If in Autostart mode, it starts the ignition cycle unless a previous lockout has taken place; if in standby mode it waits for the operator to reset the equipment.
Pilot burner	YES	First-stage gas output operating mode: INTERMITTENT (the output is left enabled until flame extinction occurs), INTERRUPTED (the output is inhibited at the end of the 2 <sup>nd</sup> safety time)
Flame loss	YES	Behaviour at flame extinction: LOCKOUT, RE-SPARK from the 1 <sup>st</sup> safety time, RE-CYCLE (only once if the flame does not come out)
Air switch	YES	Selects the air pressure switch controlling mode: INHIBITED (does not consider the input), LOCKOUT (turns the burner off and waits for the resetting signal), STOP (stop the burner until pressure is restored).
Thermostat	YES	It enables or inhibits the thermostat input.
Daily shutoff	YES	It enables or inhibits the burner to automatically shutoff for adjustment purposes within 24 hours of continuous operation, to ensure that all operating tests on the burner are carried out.
Air damper	YES	It enables the air damper to be controlled in LOCAL (considers the inputs on the expansion card), REMOTE (controls the air damper via serial drives) or INHIBITED mode (does not consider the inputs on the expansion card)

## COMMUNICATION PROTOCOL

The communication between the devices and the controlling system (PC/PLC) takes place via an interface card designed to transform a standard signal (RS232-RS422) into a ECS signal.

The communication protocol entails the use of strings made up of

ASCII characters, sent at 4,800 bauds, 8 bits, no parity, 1 or 2 stop bits.

The strings are to be sent as follows:

REMOTE DRIVE	<	S	N	C	KK		Cr
Description	Transmission preamble from PC/PLC to ESTRO	Segment that identifies the addressee from 0-9 to A-Z (capital letters) of ESTRO	Node that identifies the addressee from 0-9 to A-Z (capital letters) of ESTRO	Drive to be performed by the ESTRO flame control	Checksum value		Carriage Return
Ex.: a RUN drive is sent to equipment A0 (ASCII)	<	A	0	R	0	C	Cr
Hexadecimal characters used for the checksum calculation	3C	41	30	52			0D

**Checksum value 1 0C** It is the string checksum, calculated as the hex sum of all the characters, including the carriage return. If the result were made up of 3 or more characters, the two less significant ones would be used, they come inserted like ASCII code in the string.

REACTION FROM DEVICE	>	S	N	T	KK		Cr
Description	Reception preamble from ESTRO to PC/PLC	Segment that identifies the addressee from 0-9 to A-Z (capital letters) of ESTRO	Node that identifies the addressee from 0-9 to A-Z (capital letters) of ESTRO	Status of the ESTRO flame controlling device	Checksum value		Carriage Return
Ex.: a HALT status is received from equipment A0 (ASCII)	>	A	0	H	0	4	Cr
Hexadecimal characters used for the checksum calculation	3E	41	30	48			0D

**Checksum value 1 04** It is the string checksum, calculated as the hex sum of all the characters, including the carriage return. If the result were made up of 3 or more characters, the two less significant ones would be used, they come inserted like ASCII code in the string.

The ESA-ESTRO device answers each drive by sending its status. Collective drives to several devices can also be sent.

Segment	Node	Answer from ESTRO	Description
A	B	YES	The communication takes place only with the device referred to as segment A and Node B
*	B	NO	The communication takes place with all the devices referred to as node B
A	*	NO	The communication takes place with all the devices referred to as Segment A
*	*	NO	The communication takes place with all the connected devices

#### DRIVES FROM CONTROL SYSTEM TO ESA-ESTRO DEVICE

Drive	ASCII Value	HEX Value	Description
RUN	R	52	It corresponds to the starting drive. The drive is recognized by the device only if it is in the <i>H</i> (Halt) status
HALT	H	48	It is the halting drive for the burner. It is recognized when the device is on
UNLOCK	B	42	It corresponds to the reset drive of the device. It is recognized when it is in the <i>S</i> (Stop) status
STATUS	S	53	It corresponds to the drive for request of information on the current status.
MAIN ON	M	4D	It allows the 2 <sup>nd</sup> stage burner to be turned on, when it is off (from stage 2 to stage 3)
2° STAGE ON	m	6D	It allows the 2 <sup>nd</sup> stage burner to be turned off, when it is on (from stage 3 to stage 2)
2° STAGE OFF	K	4B	It turns off the 2 <sup>nd</sup> stage burner, and turns on the first one (from stage 4 to stage 2)
Something RUNNING	?	3F	It corresponds to the request for burner on. It can be used for collective requests, and the positive answer is a "NUL" (hex00) character
Something LOCKED	!	21	It corresponds to the request for locked out burner. It can be used for collective requests, and the positive answer is a "NUL" (hex00) character

**ANSWERS FROM ESTRO TO CONTROL SYSTEM**

Answer	ASCII Value	HEX Value	Description
STOP	S	53	The burner is locked out. One sole code is used in order to make the analysis of the answer easier. The burner could be in a <i>F, d, S, U</i> or <i>O</i> lockout.
REMOTE HALT	H	48	The burner is not working due to a previous request for Halt.
PURGE	P	50	Combustion chamber prepurge in progress or awaiting phase before ignition
IGNITION TRIAL	1	31	Ignition of the 1 <sup>st</sup> stage burner.
1 STAGE ON	2	32	Control of the flame stability of the 1 <sup>st</sup> stage burner
1 AND 2 STAGE ON	3	33	1 <sup>st</sup> and 2 <sup>nd</sup> stage burner on. This phase may be temporary (discontinuous 1 <sup>st</sup> stage burner mode) or definitive
ONLY 2 STAGE ON	4	34	1 <sup>st</sup> stage burner off and 2 <sup>nd</sup> stage burner on
POSTPURGE WAITING	W	57	Burner off during post purge phase
PROBE TEST	Y	59	Detection probe test after burner is turned off

**DRIVES FROM CONTROL SYSTEM TO ESA-ESTRO DEVICE EQUIPPED WITH EXP-1 EXPANSION CARD**

Drive	ASCII Value	HEX Value	Description
GO TO PURGE	G	47	It starts the prepurge phase ( <i>P</i> ).
GO TO IGNITION	g	67	It starts the ignition phase ( <i>i</i> ).

**ANSWERS FROM ESTRO TO CONTROL SYSTEM EQUIPPED WITH EXP-1 EXPANSION CARD**

Answer	ASCII Value	HEX Value	Description
THERMOSTAT	t	74	Lockout request from thermostat
AIR SWITCH FAIL	@	40	Lockout due to air pressure switch fail
AIR PRESS WAITING	A	41	Waiting for consent from air pressure switch
OPEN AIR DAMPER	O	30	Request for opening from the device to the controller in order to force the air damper into the hi-fire position for the prepurge phase
CLOSE AIR DAMPER	C	43	Request for closing from the device to the controller in order to force the air damper into the lo-fire position for burner ignition

## DIMENSIONS

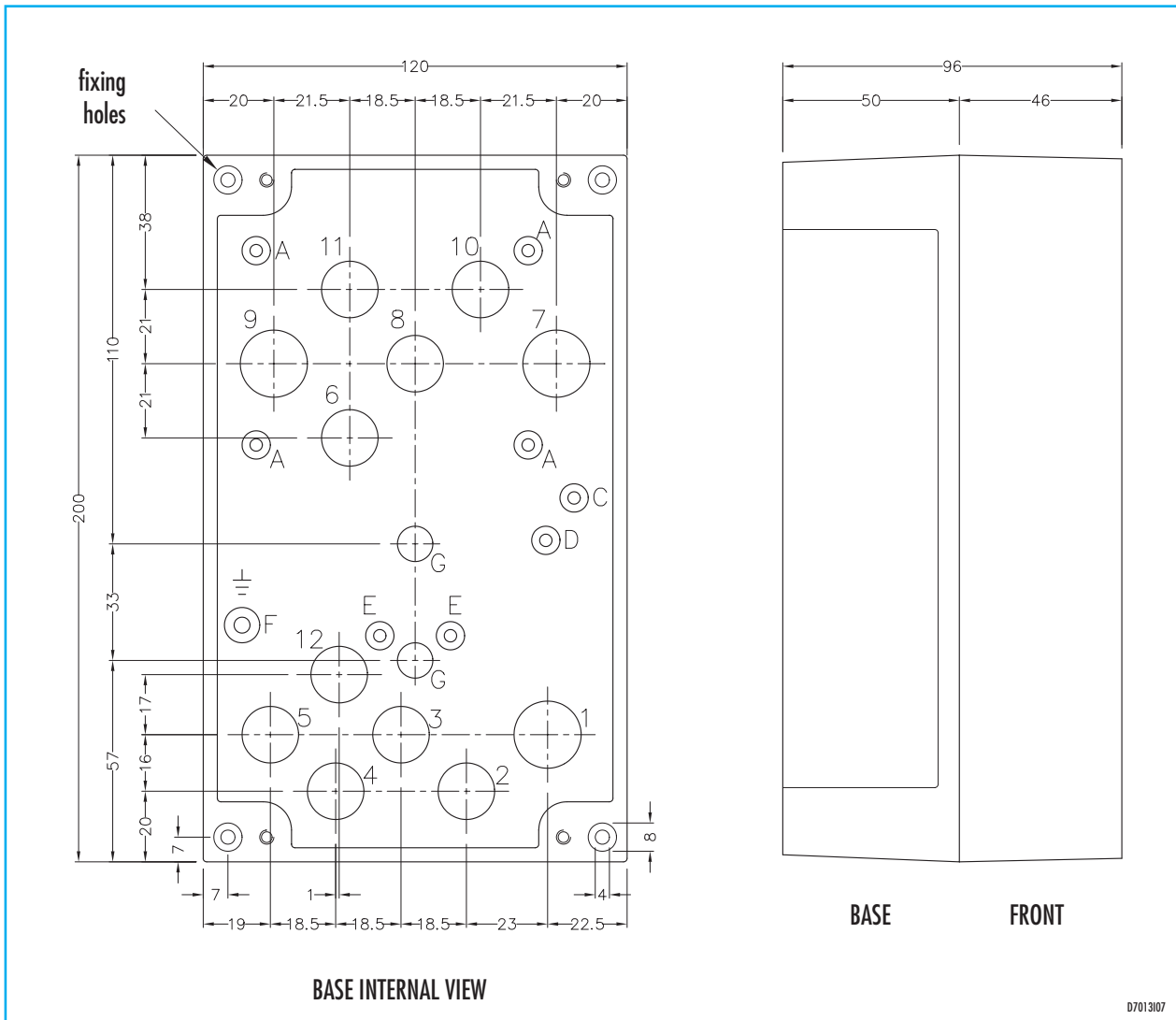

Preformed holes	Diameter mm	Connector
1	19	PG 11
2 - 3 - 4 - 5 - 12	16	PG 9
6 - 8 - 10 - 11 *	16	PG 9
7 - 9 *	19	PG 11

\* When transformer is present, it is not possible to use preformed holes No. 6÷11

Item	Description
A	lugs for transformer TAR-10 *
C	available
D	available
E-E	available
F	terminal for grounding
G-G	fixing holes for collar (pipes $\varnothing 1/2''$ ) - screw M6

When EXP-1 expansion card is present, it is not possible to assemble ignition transformer inside ESA ESTRO; in this case you have to use ESA TRAF0 box (see bulletin E5004).

## ORDERING CODE

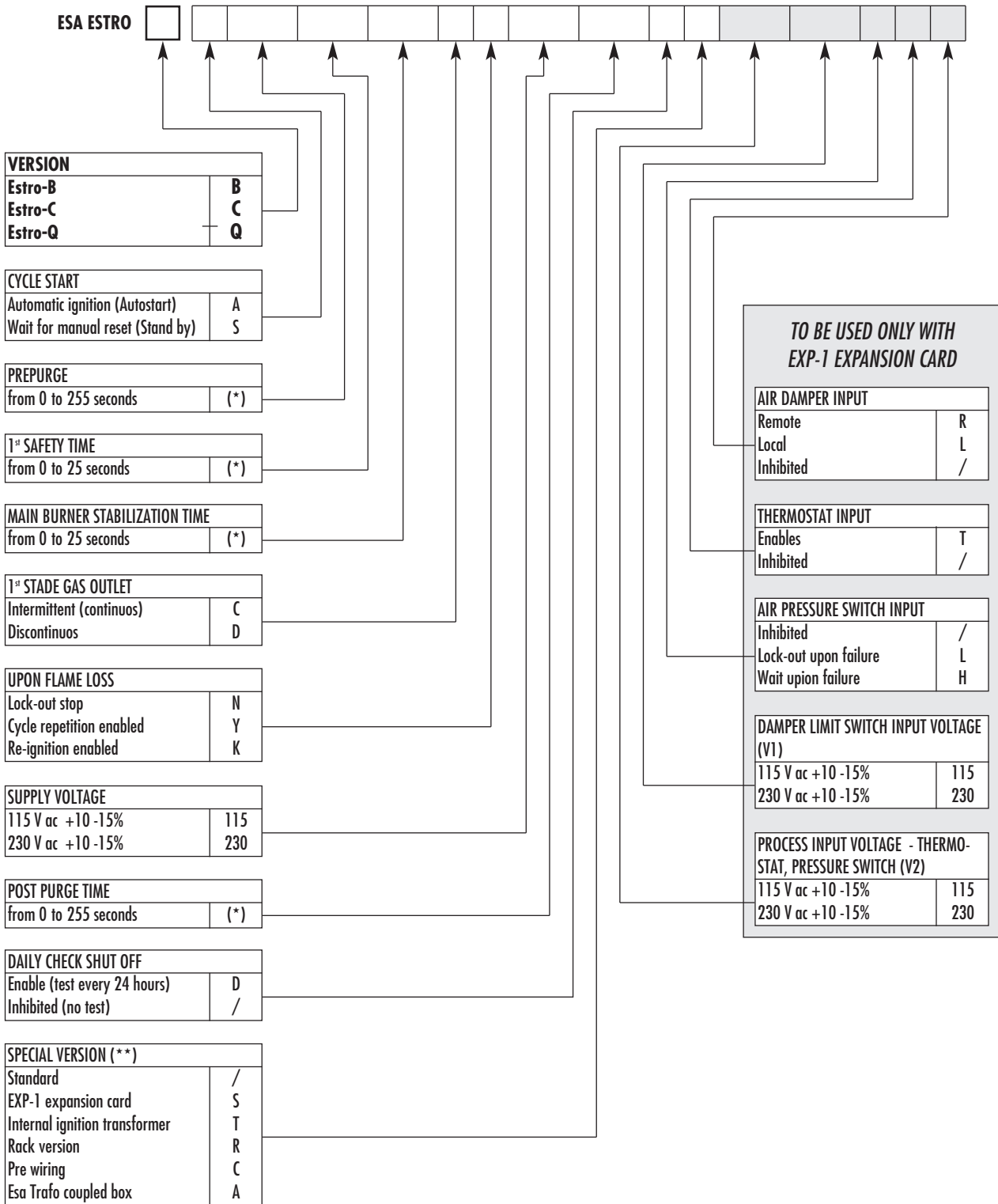

(\*) Please, write time value (in seconds)  
 (\*\*) More than one code can be used, but 'S' and 'T', that are incompatible (see "Dimensions")



NOTE: Based on the company's policy aimed at a continuous improvement on product quality, ESA-PYRONICS reserves the right to bring changes to the technical characteristics of this device without previous notice. Our catalog updated to the latest version is available on our web site [www.esapyronics.com](http://www.esapyronics.com) and it is possible to download modified documents

WARNING: When operating, this combustion system can be dangerous and cause harm to persons or damage to equipment. Every burner must be provided with a protection device that monitors the combustion. The installation, adjustment and maintenance operations should only be performed by trained and qualified personnel.