

## SURELINK CONTROL VALVE SCV SERIES

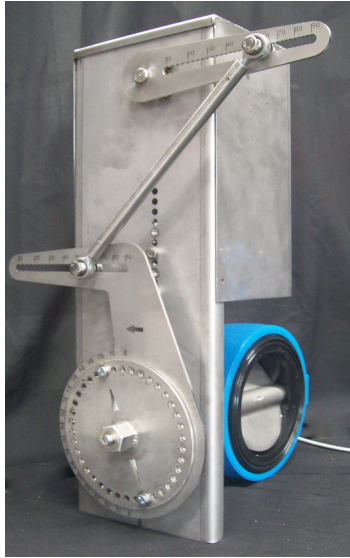

### *SureLink*

SureLink is ideal as a combustion air control valve when using a ratio regulator system or as a gas control valve on an excess air system. It allows the start position and range of angular travel to be set independently. This is achieved mechanically using the unique graduated linkage system.

	W	L	H	D
	mm	mm	mm	mm
SCV-50	199	42.9	410	100
SCV-65	211	46	410	120
SCV-80	218	46	410	127
SCV-100	237	52.3	410	156
SCV-125	250	55.6	410	190
SCV-150	262	55.6	410	212
SCV-200	300	60.5	410	268
SCV-250	332	68.3	410	325
SCV-300	370	77.7	410	403

### FEATURES

- Suitable for air or gas
- Low cost and simple to use
- Quick to set-up using the predetermined linkage
- Accurate setting of low and high fire valve positions
- Recordable commissioned settings
- Stainless steel arms, frame and motor rain cover
- Control 0(2) - 10 VDC or 0(4) - 20 mA
- Power 230 VAC (24 VDC option)
- Open and closed limit motor switches (2 x SPDT)
- Assembly is complete with motor and wafer valve

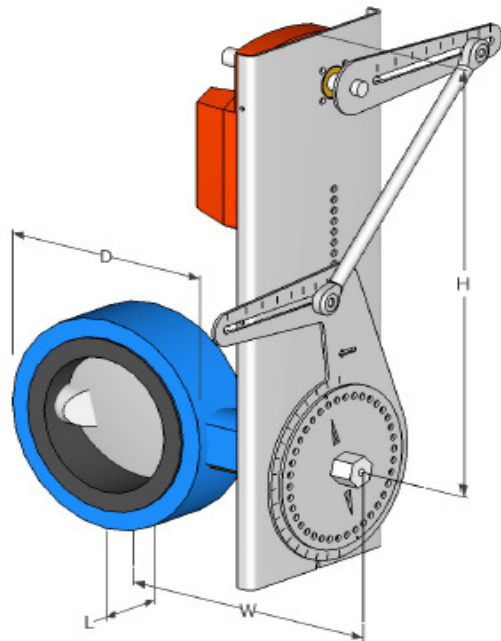

WARNING: SureLink is not an isolation or shut-off valve

**Australian Burner Manufacturers**  
2 / 2 Access Way, Carrum Downs VIC 3201  
Telephone +613 9770 8545  
Facsimile +613 9770 8546  
Email [info@australianburners.com](mailto:info@australianburners.com)