

BIOGAS WATER HEATER

BWH SERIES

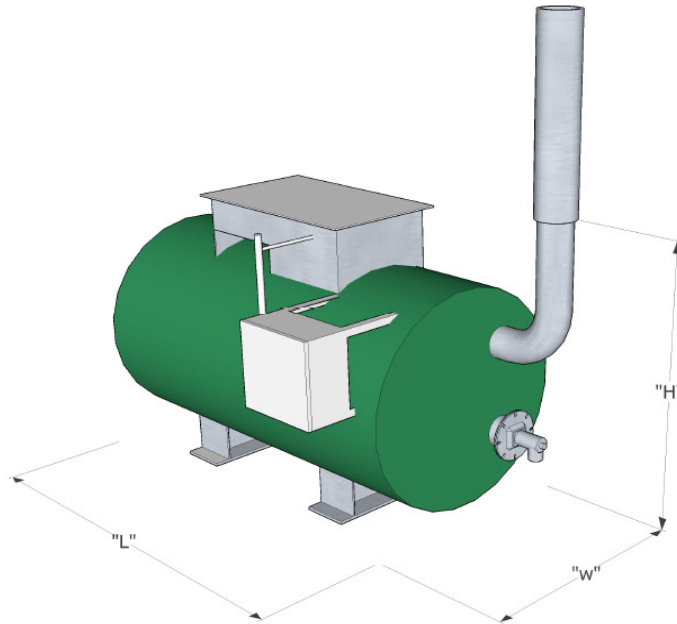

FEATURES

- Fired on biogas
- 70% Efficiency
- 60 - 90°C water temperature set point
- Water Temperature control
- Destruction level +99%
- Fully automatic
- Interrupted LPG pilot
- Self checking flame detection
- Double Block Gas train
- Flame arrestor
- Insulated Shell

| | BIOGAS VOLUME 60%CH ₄ m ³ /h | W mm | L mm | H mm | Fire tube withdrawal distance | HEAT TO WATER kW |
|--------|--|---------|---------|---------|-------------------------------------|---------------------|
| BWH-12 | 27 | 1200 | 2300 | 1600 | 1700 | 120 |
| BWH-25 | 56 | 1500 | 3500 | 1900 | 2900 | 250 |
| BWH-50 | 113 | 1500 | 6000 | 1900 | 5400 | 500 |

OPTIONS

- Biogas knock out pot
- Biogas fan
- Auto water filling
- Water pump

Australian Burner Manufacturers
 2 / 2 Access Way, Carrum Downs VIC 3201
 Telephone +613 9770 8545
 Facsimile +613 9770 8546
 Email info@australianburners.com

